



**Łukasiewicz**  
Instytut Tele-  
i Radiotechniczny

## ULTRASONIC GENERATOR SONIC BLASTER PLUS

type: SBP520, SBP320, SBP220, SBP230, SBP240, SBP250



### OPERATING MANUAL

DOCUMENT NO.	61731
DOCUMENT REVISION	8.01
UPDATE	19.05.2023
SOFTWARE VERSION	2.0.0

### PATENTS, UTILITY DESIGNS AND PATENT APPLICATIONS

Pat.215708, Pat.217106, Pat.217491, Pat.220100, Pat.223774, Pat.223867,  
Pat.225673, Pat.225674, Pat.217489, Pat.218988

**Table of contents:**

1.	Introduction.....	3
1.1.	Symbols .....	3
1.2.	Safety.....	3
2.	General .....	4
3.	Installation method .....	5
3.1.	Connection to the mains .....	5
3.2.	Connection to the vibration system .....	5
3.3.	Connection of SBE1 I/O card control lines.....	6
3.3.1.	Analogue inputs/outputs.....	6
3.3.2.	Digital inputs/outputs.....	7
4.	Operating instructions.....	11
4.1.	Generator functions control panel .....	11
4.1.1.	WELDING window .....	14
4.1.2.	PROGRAMME parameter setting window .....	17
4.1.3.	Welding mode selection window .....	20
4.1.4.	Numerical value editing window .....	21
4.1.5.	Measurement, protection and scanning results window .....	22
4.1.6.	Login window .....	26
4.1.7.	Recorder window .....	28
4.1.8.	Event log window .....	35
4.1.9.	Settings Window.....	36
4.1.10.	Date and time setting window .....	42
4.1.11.	Help Window .....	42
4.2.	Generator Update .....	43
4.3.	Preparing a backup of the generator settings .....	44
4.4.	Generator start.....	45
5.	Technical data.....	46
6.	Manufacturer's comments .....	49
6.1.	Maintenance, periodic inspections and repairs.....	49
6.2.	List of spare parts delivered on request .....	49
6.3.	OHS instructions .....	49
6.4.	Storage and transport .....	49
6.5.	Disposal .....	50
7.	Contact us.....	52

## 1. Introduction

### 1.1. Symbols

In order to become familiar with the generator, please read this operating manual before use. This will ensure its safe and proper operation.



Electrical warning sign indicating important information regarding the presence of a hazard that could cause an electrical shock.



Warning sign indicating important information about a hazard that may cause damage to the device or its malfunction.



Information sign highlights important device features and parameters.

### 1.2. Safety



The national and industry safety regulations must be observed during installation and operation.

When the generator is in operation, some parts of it may be under a voltage that is dangerous to humans. Incorrect or improper use of the device can pose a danger to operators and can also damage the generator.

If the generator is improperly used or used not for its intended purpose, the user shall be fully responsible for any possible risks to safety and resulting damage.



Operating a damaged device may result in the improper functioning of the protected unit, which may result in risks to life or health.

Correct and trouble-free operation of the device requires proper transport, storage, assembly, installation and commissioning, as well as proper operation, maintenance and service.

The installation and operation of the device should only be carried out by appropriately trained personnel.



The device meets the general conditions for safe operation and bears the CE marking.



*This device cannot be disposed of with household waste.*

## 2. General



SONIC BLASTER Plus generators, types: SBP520, SBP320, SBP220, SBP230 and SBP240 are intended for use in industrial environment as components of a machine performing ultrasonic processes.

Sonic Blaster Plus generators have the following features:

- 7" touch control panel
- User access control for: operator, administrator and service;
- Control of 34 welding parameters such as active welding power, welding time, output signal amplitude;
- Measurement and visualisation of process parameters during the welding cycle;
- 10 predefined welding processes;
- Self-diagnosis of the welding machine and the ultrasonic vibration system;
- Protection functions of the ultrasonic system;
- Editing setpoints of protection functions;
- Synchronisation with external process controller using a binary interface;
- interfaces: RS485, Ethernet, USB.



*Rys.1. Sonic Blaster Plus generator view*



Before using the generator in an ultrasonic machine, it is recommended to consult with the machine manufacturer.

The SONIC BLASTER Plus generator presented in Fig. 1 is equipped with a digitally-controlled power converter, consisting of a rectifier and an inverter, which generates an output voltage signal with controlled amplitude and frequency. To stabilise the active power consumed by the load, an output signal amplitude and frequency control tracking system were used.

The SONIC BLASTER Plus generator offers extended setup capacity on the basis of a system of welding programmes. The device is equipped with 10 welding programmes with setpoints that determine the course of the welding process.

It complies with the requirements of the Directives of the European Parliament and of the Council:

Directive	Description
2014/35/UE	on the harmonisation of the laws of the Member States relating to the making available on the market of electrical equipment designed for use within certain voltage limits
2014/30/UE	on the harmonisation of the laws of the Member States relating to electromagnetic compatibility
2011/65/UE	on the restriction of the use of certain hazardous substances in electrical and electronic equipment

Standard	Description
PN-EN 601010-1:2011	Safety requirements for electrical equipment for measurement, control and laboratory use – Part 1: General requirements
PN-EN 61000-6-2:2008	Electromagnetic compatibility (EMC) – Part 6-2: Generic standards. Immunity standard for industrial environments.
PN-EN 55011:2016-05	Industrial, scientific and medical equipment – Radio-frequency disturbance characteristics – Limits and methods of measurement
PN-EN 50581:2013-03	Technical documentation for the assessment of electrical and electronic products with respect to the restriction of hazardous substances
CE	The device meets the general conditions for safe operation and bears the CE marking.

### 3. Installation method

The SONIC BLASTER Plus generator can be installed in enclosed areas which meet the corresponding general conditions related to buildings and can be operated under normal working environment conditions (effective temperature range 0-45°C, relative humidity  $\leq 75\%$  at 20 °C).

The device cannot be installed in rooms with an aggressive atmosphere, a high dust content or in hazardous areas. It should be installed in a room with a properly working ventilation system.

The ultrasonic generator should be positioned so that air can flow into the ventilation openings.

#### 3.1. Connection to the mains

The SONIC BLASTER Plus generator should be connected to the mains using the power cable attached to the generator. If the cable is to be replaced, brand new cables with IEC C19 connector and a core cross-section of at least 1.5 mm<sup>2</sup> should be used. It is possible to deliver 2 m, 3 m or 5 m power cables on special request.



The correct cabling of the generator power outlet as shown in Fig. 2 must be ensured.

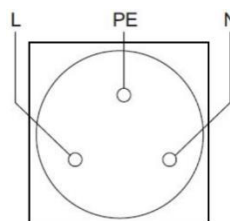

Fig. 2. Recommended power outlet cabling.



If the power supply connection needs to be extended, a three-core cable with a core cross-section not less than 1.5 mm<sup>2</sup> (2.5 mm<sup>2</sup> for SBP520) and mains sockets and plugs with a ground pin, adopted to currents equal to or higher than 16 A (32 A for SBP520) should be used.

#### 3.2. Connection to the vibration system

The SONIC BLASTER Plus generator should only be connected to the vibration system using the brand-new high-voltage connection cable (HV cable) supplied with the device. Any modifications to the HV cable or its connectors are not permitted. The HV cable length should be specified when ordering. If the HV cable provided with the generator is damaged or its length is inappropriate for a given application, a new HV cable should be delivered by the manufacturer for an extra charge.



The HV cable that connects the generator and the vibration system is terminated with a high-voltage FFB.1S.405.CTAC47 connector by LEMO, compatible with a ERA.1S.405.CTL outlet by LEMO. The vibration system must be factory-equipped with this outlet. Any modifications to the outlet and use of any adapter cables are prohibited.

### 3.3. Connection of SBE1 I/O card control lines

The SONIC BLASTER Plus generator is equipped with an SBE1 I/O card. The card is a unit that expands the Sonic Blaster Plus generator’s capabilities. It has a binary I/O interface (DB15F), an analogue I/O interface (DB9F), a RJ-45 RS-485 MODBUS RTU connector and a LAN/ETHERNET RJ-45 connector.

#### 3.3.1. Analogue inputs/outputs

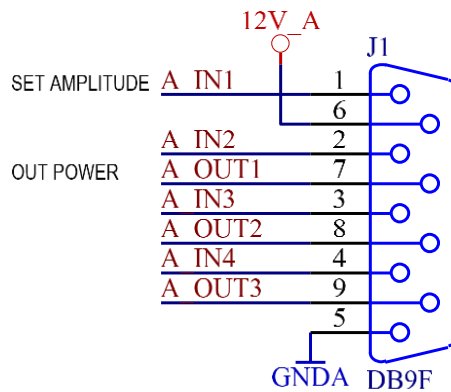

SET AMPLITUDE	SET AMPLITUDE
OUT POWER	OUT OF POWER

Fig. 3. DB9F interface diagram

Table 1. Description of signals at the analogue I/O interface

Signal name	DB9 interface pin number	Signal type	Current efficiency/consumption	Signal significance
A_IN1	1	0-10 V line input	< 0.5 mA	Set amplitude setpoint
A_IN2	2	0-10 V line input	< 0.5 mA	-
A_IN3	3	0-10 V line input	< 0.5 mA	-
A_IN3	4	0-10 V line input	< 0.5 mA	-
GND	5	Ground	-	-
12 V	6	12 V / 50 mA auxiliary power supply	50 mA	-
A_OUT1	7	0-10 V line output	max. 5 mA	Power output level
A_OUT2	8	0-10 V line output	max. 5 mA	-
A_OUT3	9	0-10 V line output	max. 5 mA	-

In standard setup, only 2 signals are used: A\_IN1 and A\_OUT1.

A\_IN1 – input signal for setting the generator’s output amplitude. The value of the input voltage applied to this input determines in a linear manner the generator’s output amplitude within a range of amplitude from 10% to 100%. If the signal level at the input is lower than 10% of the range, a value defined in the welding programme is set.

$$A_0 = U_{A\_IN1} / 10 * 100\%$$

where: A<sub>0</sub> – set generator output amplitude (in %),

U<sub>A\_IN1</sub> – voltage (in volts) at A\_IN1 line input.

Example: if 5 V is applied to A\_IN1, the generator’s output amplitude will be set to 50%.

A\_OUT1 – output signal providing the value of current power supplied by the generator to the load. The value of the output voltage corresponds linearly to the value of the power output (in watts) within a range from 0 to the maximum power output of a given type of generator (3000 W for SBP320, 5000 W for SBP520 etc.). Example: 1 V in SBP320 means that the current power output is 300 W.

12 V / 50 mA auxiliary power supply – the unit is equipped in an internal insulated power supply unit with a voltage of 12 V ±5%. This voltage is available at the DB9 interface and may be used to supply additional circuits, whereas the total current consumption of the circuits connected cannot exceed 50 mA.

### 3.3.2. Digital inputs/outputs

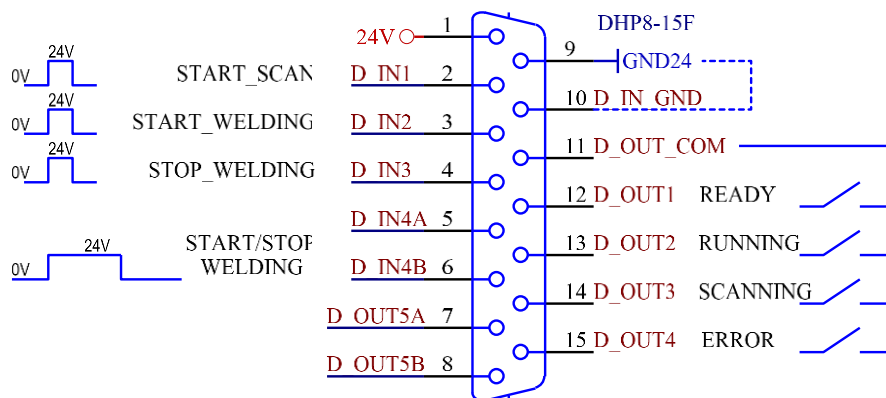

READY	READY
RUNNING	RUNNING
SCANNING	SCANNING
ERROR	ERROR
START/STOP	START/STOP
WELDING	WELDING
START_SCAN	START_SCAN
START_WELDING	START_WELDING
STOP_WELDING	STOP_WELDING

Fig. 4. DB15F interface diagram

Table 2. Description of signals at digital I/O interface

Signal name	B15 interface pin number	Signal type	Current efficiency/consumption	Signal significance
24 V	1	24 V power supply output	1.5A	
D_IN1	2	0-24 V binary output	< 0.5 mA	Scanning start
D_IN2	3	0-24 V binary output	< 0.5 mA	Welding start
D_IN3	4	0-24 V binary output	< 0.5 mA	Welding stop
D_IN4A	5	0-24 V floating binary output	< 0.5 mA	Welding start/stop
D_IN4B	6			
D_OUT5A	7	Floating relay output	1A/48VAC	-
D_OUT5B	8			

GND24	9	24 V power supply ground	-	-
D_IN_GND	10	Ground of inputs 1...3	-	-
D_OUT_COM	11	Common contact of outputs 1..4		
D_OUT1	12	NO relay output	1A/48VAC	Standby
D_OUT2	13	NO relay output	1A/48VAC	Welding
D_OUT3	14	NO relay output	1A/48VAC	Scanning
D_OUT4	15	NO relay output	1A/48VAC	Error

- D\_IN1 – the application of a positive impulse with a duration of > 100 ms triggers the activation of the generator scanning process, exactly as it is after switching on the power supply. This occurs only when the generator on standby and the welding process is not in progress.
- D\_IN2 – the application of a positive impulse with a duration of > 100 ms triggers the activation of the welding process according to the preset programme (start at impulse).
- D\_IN3 – the application of a positive impulse with a duration of > 100 ms triggers the deactivation of the welding process, if in progress (stop at impulse).
- D\_IN4 – the application of a high state triggers the activation of the welding process according to the preset programme, whereas the application of low state, if a high state was previously applied at this input, triggers the deactivation of the welding process (start/stop at level). NOTE Floating output – state should be applied between D\_IN4A and D\_IN4B pins with any polarity.
- D\_OUT1 – a closed contact indicates generator standby (power supply on, scanning completed).
- D\_OUT2 – a closed contact indicates that the welding process is in progress.
- D\_OUT3 – a closed contact indicates that the scanning process is in progress.
- D\_OUT4 – a closed contact indicates that an error occurred.
- 24 V – 24 V DC / 1.5 A auxiliary power supply output which can be used to supply an external automation system.

### 3.4. RS-485 MODBUS RTU communication interface

The generator is equipped with an RS-485 communication interface that supports MODBUS RTU transmission. The I/O card has a RJ-45 connector, designated as RS-485. It is compatible with a UTP twisted pair. A connection diagram is presented in Fig. 5.

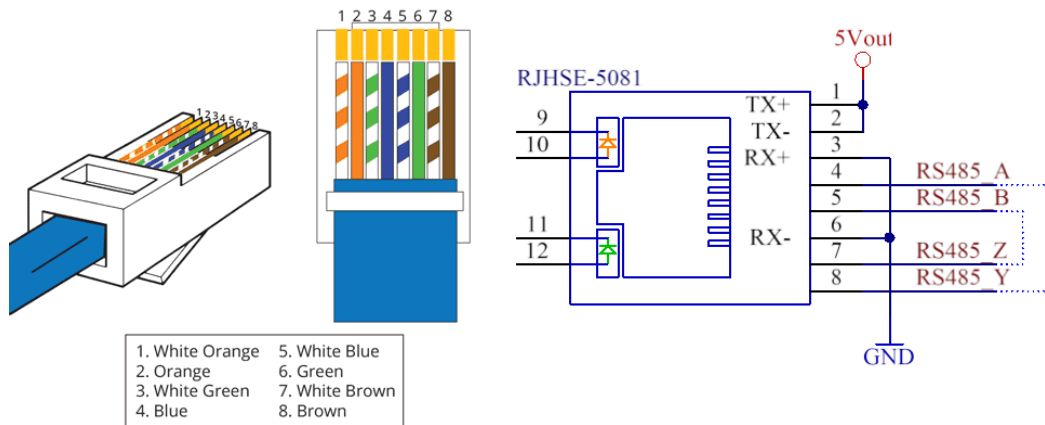

Voul	Voul
White Orange	White Orange
Orange	Orange
White Green	White Green
Blue	Blue
White Blue	White Blue
Green	Green
White Brown	White Brown
Brown	Brown

Fig. 5. RJ-45 interface diagram and RS-485 interface cable and plug diagram



Transmission and reception lines are separated at this interface. To operate using RS-485, the appropriate lines should be interconnected (as indicated with the broken line on the diagram). 5 V auxiliary output voltage with a current efficiency of 100 mA is available at this interface.



To activate the MODBUS RTU communication unit, set the activity switch in the RS-485 position in the SETTINGS menu to active (green) by clicking it.

## MODBUS RTU

### RS-485/RS-422 transmission

**Configuration:** 8 data bits, no parity, 1 stop bit

**Bitrate:** 9600 bps (to change, go to SETTINGS -> RS-485)

**Generator address:** 0xAA (to change, go to SETTINGS -> RS-485)

### Available commands:

FC 03 – Read n setup registers

FC 04 – Read n input registers

FC 06 – Store one setup register

FC 16 – Store n setup registers

### Register map:

#### Input registers (read-only, FC 04 command), numbers from 30001:

30001: uint16 status;	status bit field: (adr:0)
	GEN_IDLE 0x00 – Generator on standby, not welding
	GEN_SCANNING 0x01 – Generator scanning
	GEN_WELDING 0x02 – Generator welding
	GEN_ERROR 0x03 – (Protection) error occurred
	GEN_MAINS 0x04 – Mains supply on (in parallel with others)
	GEN_SCAN_OK 0x08 – Scanning completed and correct (in parallel with others)
	E.g. 0x12 =0x00+0x04+0x08 – Generator on standby, power supply on, scanning correct
	E.g. 0x14 =0x02+0x04+0x08 – Generator welding, power supply on, scanning correct
30002: uint16 power;	Power in watts (0–3000)
30003: uint16 amplitude;	Amplitude with a resolution of 0.1% (range 0-1000)
30004: uint16 Uout;	Output voltage in volts
30005: uint16 Iout;	Current in mA (0.001 A)
30006: uint16 Zout;	Instantaneous impedance of the vibration system in $\Omega$
30007: uint16 Zph;	Instantaneous impedance phase in degrees

### Protections:

30008: uint16 protection;	Protection trip code (error code: 0 – none, 1 – voltage protection, 2 – current protection)
30009: uint16 Uprot;	RMS voltage value at protection activation
30010: uint16 I_prot;	RMS current value at protection activation

### Scanning results (32-bit registers treated as 2 MODBUS registers):

30011: uint32 f_ser;	Scanned frequency of series resonance
30013: uint32 z_ser;	Scanned impedance in series resonance

30015: uint32 f\_par; Scanned frequency of parallel resonance  
 30017: uint32 z\_par; Scanned impedance in parallel resonance  
 30019: uint32 f; Current operating frequency

**Control line value preview (SBE1 I/O card)**

30021: uint16\_t data\_valid; Correctness of digital input/output data (bit 0) and analogue input/output data (bit 1), value 0x03 — all data correct  
 30022: uint16\_t dig\_in; Binary inputs, successive bits correspond to successive inputs, number of inputs = 4 (bit 0..3)  
 30023: uint16\_t dig\_out; Binary outputs, successive bits correspond to successive outputs, number of inputs = 5 (bits 0..4), READ ONLY

30024: uint16\_t analog\_in\_1;  
 30025: uint16\_t analog\_in\_2;  
 30026: uint16\_t analog\_in\_3;  
 30027: uint16\_t analog\_in\_4;

} Analog inputs 1–4, 0–10 V range, 1 mV unit (10 V = 10000)

30028: uint16\_t analog\_out\_1;  
 30029: uint16\_t analog\_out\_2;  
 30030: uint16\_t analog\_out\_3;

} Analog outputs 1–3, 0–10 V range, 1 mV unit (10 V = 10000), READ ONLY

**Setup registers (read-only, FC 03, FC 06, FC 16 commands), numbers from 40001:**

40001: uint16 start\_stop; 0 – welding or scanning stopped, if previously activated using MODBUS  
 1 – scanning start  
 2 – scanning stop  
 4 – welding or scanning totally stopped, even if previously activated without using MODBUS  
 40002: uint16 set\_power; Set power in watts (0-3000)  
 (in amplitude mode, it acts as power limiter)  
 40003: uint16 set\_amplitude; Set amplitude in 0.1% (range 0-1000, that is 0.0%-100.0%) (in power mode, it acts as amplitude limiter)

## 4. Operating instructions

### 4.1. Generator functions control panel

The Sonic Blaster Plus generator is equipped with a 7-inch TFT graphical display with a touch panel and a graphical user interface with 'tiles'. By clicking any 'tile', the corresponding menu can be accessed.

The Sonic Blaster Plus generator control panel is presented in Fig. 6. The items on the panel are divided into four main categories. Their meanings are explained in Tables 3-6.

Category	Name	Description
A	Signalling pictogrammes	Diodes indicating the operating status of the device
B	Communication interfaces	User accessible hardwired communication interfaces
C	Quick access icons	Icons for quick access to the selected user menu
D	Working screen	Working screen containing information for a given user menu level



Sonic blaster plus	Sonic blaster plus
ZGRZEWANIE	WELDING
REJESTRATOR	RECORDER
DZIENNIK	LOG
POMIARY	MEASUREMENTS
PROGRAMY	PROGRAMMES
USTAWIENIA	SETTINGS
LOGOWANIE	LOGIN
ZEGAR	CLOCK
POMOC	HELP
Modbus	Modbus

Fig. 6. Front panel view with a description of main items

Table 3. Signalling pictogrammes (Category A)

Icon	Name	Description
------	------	-------------















	POWER SUPPLY	Indicates the presence of the generator's supply voltage.
	STANDBY	Indicates the generator's readiness for operation. Denotes that the vibration system scanning process was successfully completed.
	OPERATION	Indicates the generator's operation (welding process or tuning). Denotes the presence of high voltage at the generator output.
	ERROR	Indicates the occurrence of an error (activation of any of the protections) during the welding process.

Table 4. Communication interfaces (Category B)

Port	Name	Description
Mini USB	Mini USB	An interface to connect a PC to transfer files.
Type-A USB	USB	An interface to connect a mass storage device (e.g. USB flash drive). It is possible to copy files from the panel's internal memory or update the generator software.

Icon	Name	Description
	STATUS	Current device status: FAILURE/OPERATION/STANDBY (red/orange/green)
<b>P1, P2, P3...</b>	PROGRAMME	Active Welding PROGRAMME Press the PROGRAMME icon to access the PROGRAMME menu
	USER - USER	Icon for a logged-in user with USER rights. Press the USER icon to access the LOGIN menu.
	USER - CLIENT SERVICE	Icon for a logged-in user with CLIENT SERVICE rights. Press the USER icon to access the LOGIN menu.
	USER - ITR SERVICE	Icon for a logged-in user with ITR SERVICE rights. Press the USER icon to access the LOGIN menu.
	USER - ADMINISTRATOR	Icon for a logged-in user with ADMINISTRATOR rights. Press the USER icon to access the LOGIN menu.
	RECORDER	Press the RECORDER icon to access the RECORDER menu.
	LOG	Press the LOG icon to access the LOG menu
	USB	Icon for enabled/disabled USB communication. Press the icon to access the SETTINGS menu.
	WIFI	Icon for enabled/disabled WIFI communication. Press the icon to access the SETTINGS menu.
	ETHERNET	Icon for enabled/disabled ETHERNET communication. Press the icon to access the SETTINGS menu.



 MODBUS	MODBUS	Icon for enabled/disabled MODBUS communication. Press the icon to access the SETTINGS menu.
	PRINT SCREEN	Press the icon to take a snapshot of the screen to a Flash Drive or SD memory card if no external memory is connected.
14:09:22 10.12.2018	TIME/DATE	Current time and date.

Table 5. Quick access icons (Category C)

Table 6. Working screen icons (Category D)

Icon	Name	Description
	WELDING	Access the menu with basic information on the welding process.
	RECORDER	Access the menu with the recording of the welding process parameters.
	LOG	Access the event log menu.
	MEASUREMENTS	Access the menu with information on the measurements, protections and scanning results of the ultrasonic vibration system.
	PROGRAMMES	Access the menu with the selection of predefined welding programmes.
	SETTINGS	Access the welding machine settings menu.
	LOGIN	Access the user login menu with defined access levels.
	CLOCK	Access the time and date settings menu.
	HELP	Information on the device and supplier.

#### 4.1.1. WELDING window

The WELDING window (Fig. 7) displays basic information on the welding process, enables the welding process to be manually started or stopped and allows for the ultrasonic vibration system scanning process to be activated.

The WELDING menu allows direct access to the PROGRAMMES menu (Fig.7. A) and MEASUREMENT menu (Fig. 7. B).

The WELDING menu item contains a list of entries, divided into three pages. Individual pages may be navigated using up/down arrow keys (Fig.7. C) in the window title bar.

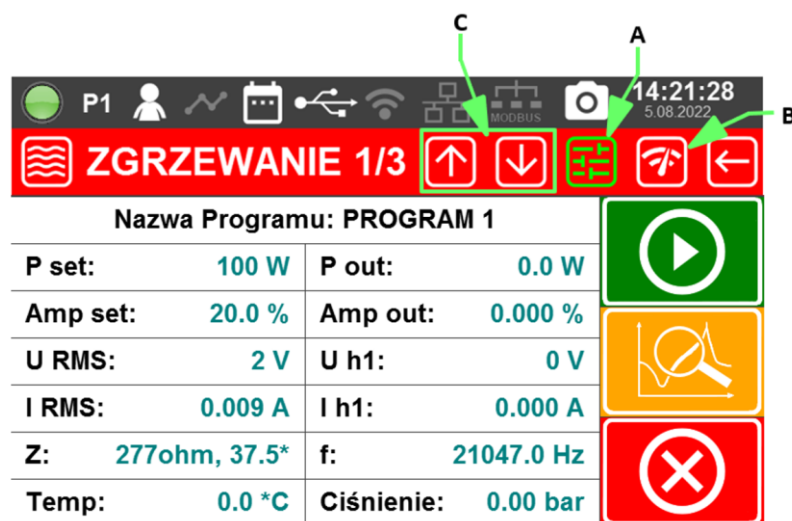

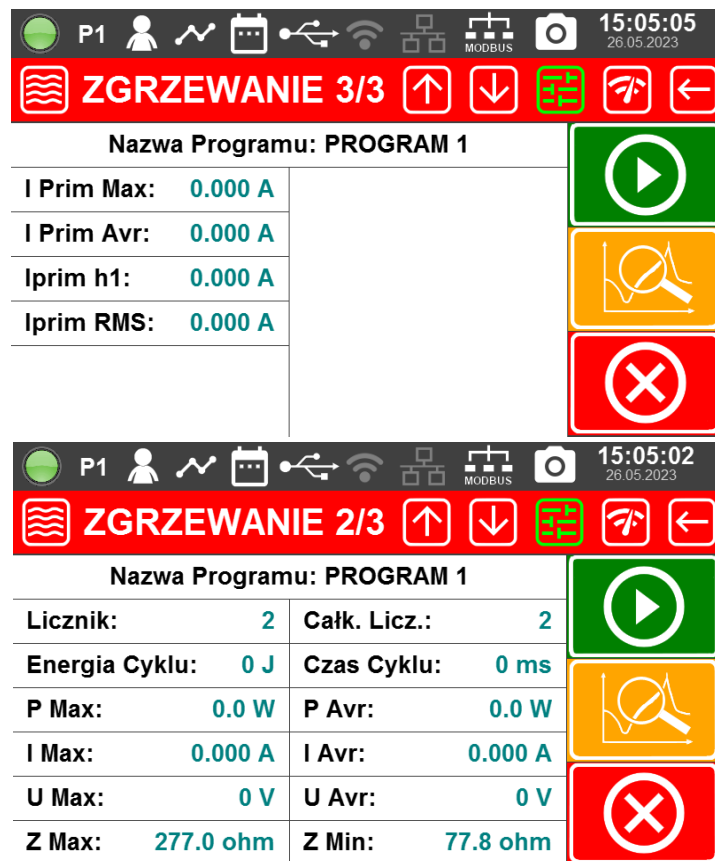



ZGRZEWANIE	WELDING
MODBUS	MODBUS
Nazwa Programu: PROGRAM 1	Programme name: PROGRAMME 1
P set	P set
Amp set	Amp set
U RMS	U RMS
I RMS	I RMS
Z	Z
Temp	Temp
P out	P out
Amp out	Amp out
U h1	U h1
I h1	I h1
f	f
Ciśnienie	Pressure
I Prim Max	I Prim Max
I Prim Avr	I Prim Avr
Iprim h1	Iprim h1
Iprim RMS	Iprim RMS
Licznik	Counter
Energia Cyklu	Cycle Energy
P Max	P Max
I Max	I Max
U Max	U Max
Z Max	Z Max
Całk. Licz.	Total Count
Czas Cyklu	Cycle Time
P Avr	P Avr
I Avr	I Avr
U Avr	U Avr
Z Min	Z Min

Fig. 7. WELDING menu

Table 7. WELDING menu icons and parameters

Icon	Name	Description
	Welding start	Press the icon and the active welding programme is enabled. If the icon turns grey, this indicates an ultrasonic vibration system scanning failure.
	Scanning start	Press the icon and the scanning process for the ultrasonic vibration system parameters is started. If the icon turns grey, this indicates an ultrasonic vibration system scanning failure.
	Welding stop	Press the icon and the ultrasonic vibration system's active welding or scanning programme is stopped.

Parameter	Description
<b>Page 1</b>	
Programme Name:	Name of the active programme according by which the welding process takes place.
P set	The target output power of the generator that the generator will attempt to achieve when operating in power control mode
P out	Instantaneous measured generator power output value actually supplied to the load.
Amp set	Target and maximum output amplitude
Amp out	Measured instantaneous output amplitude value.
U RMS	Measured instantaneous RMS voltage value of the generator output signal
U h1	Measured instantaneous RMS value of the first harmonic of the generator output signal voltage
I RMS	Measured instantaneous RMS value of the generator output signal current
I h1	Measured instantaneous RMS value of the first harmonic current of the generator output signal
Z	Electrical impedance of the load in Euler notation, module and phase
f	Current output signal frequency.
Temp	Ultrasonic transducer temperature (if measured, otherwise 0)
Pressure	Current clamping cylinder pressure (if a digitally-controlled pressure controller is used; otherwise 0).
<b>Page 2</b>	
Counter	The welding cycle counter, the counter is reset when the generator is switched on/off or by the user. To clear the counter, click on the "Counter" field and a message box appears, or reset the number of welds, the current counter value is cleared.
Ocr1 Count	Total number of generator welds counter
Cycle Energy	Total energy supplied by the generator during the signal generation cycle
Cycle Time	Total duration in the signal generation cycle
P Max	Maximum power value obtained during the signal generation cycle

P Avr	Average power value obtained during the signal generation cycle
I Max	Maximum current value obtained during the signal generation cycle
I Avr	Average current value obtained during the signal generation cycle
U Max	Maximum voltage value obtained during the signal generation cycle
U Avr	Average voltage value obtained during the signal generation cycle
Z Max	Maximum electrical impedance value obtained during the signal generation cycle
Z Min	Average electrical impedance value obtained during the signal generation cycle

### Page 3

I Prim Max	Maximum value of the generator primary current obtained during the signal generation cycle
I Prim Avr	Average value of the generator primary current obtained during the signal generation cycle
Iprim h1	Measured momentary RMS value of the generator primary current
Iprim RMS	Measured instantaneous RMS value of the first harmonic of the generator primary current

#### 4.1.2. PROGRAMME parameter setting window

In the PROGRAMMES menu (Fig. 8), one of the ten predefined welding programmes can be selected. The programmes can be defined when, for example, using multiple tools, when changing the material of a workpiece or during welding of different workpieces using one tool.

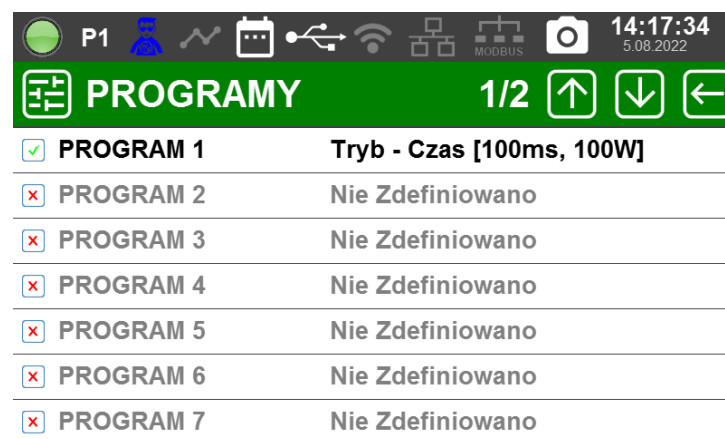

PROGRAMY	PROGRAMMES
MODBUS	MODBUS
PROGRAM	PROGRAMME
Tryb-Czas [100ms, 100W]	Mode-Time [100 ms, 100 W]
Nie Zdefiniowano	Not defined

Fig. 8. PROGRAMMES menu

The welding machine operates on the basis of the parameters defined in the active programme.

Click a given setpoint to access the value setting window (Fig. 9). For continuous welding in amplitude mode, a constant output amplitude is maintained, unless the value of the power output exceeds the set value P. In this case, the amplitude is reduced to keep the set power (power limiter).

The Welding programme parameter setting window contains a list of entries divided into three pages. The individual pages can be navigated using the up/down arrow keys on the window title bar.



PROGRAM 1					
Tryb:	Czas	Th:	0 ms	Amp. Start:	20.0 %
P1:	100 W	P2:	0 W	P3:	0 W
T1:	100 ms	T2:	0 ms	T3:	0 ms
Amp1:	20.0 %	Amp2:	20.0 %	Amp3:	20.0 %
Phi1:	0.0 deg	Phi2:	0.0 deg	Phi3:	0.0 deg
Dezaktywuj Konfigurację			Aktywny Program		



PROGRAM 1			
f min:	19000 Hz	f max:	21000 Hz
df:	50 Hz	Reg. Moc:	<input type="checkbox"/>
Szybkość Reg. Moc:	1.0x	Szybkość Reg. Częst.:	1.00x
Max Energia:	0 J	Próg Walid. Energ.:	0 %
Walidacja Energii:	<input type="checkbox"/>	Ciśnienie Sonotrody:	0.0 bar
Dezaktywuj Konfigurację		Aktywny Program	





PROGRAM 1			
UB:	1000 V	P:	1000 W
IA:	2.5 A	IB:	2.0 A
IC:	2.0 A	Tc:	70 °C
Z min:	400 ohm	Z Max:	+INF ohm
Z min Start:	200 ohm	OvrCurrThresh:	0.75x
Dezaktywuj Konfigurację		Aktywny Program	

PROGRAMY	PROGRAMMES
MODBUS	MODBUS
PROGRAM	PROGRAMME
Tryb	Mode
P1	P1
T1	T1
Amp1	Amp1
Phi1	Phi1
Czas	Time
Th	Th
Amp. Start	Amp. Start
Dezaktywuj Konfigurację	Deactivate Configuration
Aktywny Program	Active Programme
fmin	fmin
df	df
Szybkość Reg. Moc	Reg. speed Power
Max Energia	Max Energy

Walidacja Energii	Validation of Energy
f max	f max
Reg. Mocy	Reg. Power
Szybkość Reg. Częst.	Reg. speed Freq.
Próg Walid. Energ.	Valid. threshold Energ.
Ciśnienie Sonotrody	Sonotrode pressure
UB	UB
IA	IIA
IC	IC
Z min	Z min
Z min Start	Z min Start
P	P
IB	IB
Tc	Tc
Z Max	Z Max
OvrCurrThresh	OvrCurrThresh

Fig. 9. The Welding programme parameter setting window

Table 8. PROGRAMMES menu icons and parameters

Icon	Name	Description
	Programme active	Active programme by which the welding process is performed. Only one programme can be active at a time.
	Programme defined	Programme configured, inactive.
	Programme not defined	Programme not configured, inactive.

Parameter	Description
PROGRAMME 1	Click on the programme name to edit it. This name will also be displayed in the WELDING window.
Active programme	Sets the programme as currently in use (the following welding cycle will use this programme).
Enable/disable setup	Sets the programme as defined and accessible. If this item is available, it means that the programme has not been set as active so far.

**Page 1**

Mode	Enables the selection of one of the three operating modes: CONTINUOUS OPERATION / TIME / ENERGY
P1, P2, P3	When power stabilisation mode is activated, this parameter defines the value of the target process power that the generator will try to achieve during a given welding process point 1, 2 and 3 in sequence. The output power can be lower than this value if another, set parameter is reached (e.g. the amplitude of a given welding process point Amp1, Amp2, Amp3).
T1, T2, T3	Duration of a given stage of the welding process sequentially 1, 2 and 3, The duration of the process can be shorter than this value if another preset parameter (e.g. energy) is reached earlier.
Amp. Start	The start amplitude of the generator control signal, this is the amplitude that the generator forces at the output at start-up where the generator operating point is far from the target operating point of the generator outside the resonance characteristics of the vibration system.
Amp1, Amp2, Amp3	Specifies the maximum (for an amplitude-based power controller) or target amplitude of the control signal for a given point in the welding process successively 1, 2 and 3
Phi1, Phi2, Phi3	Maximum (for a phase-based power controller) or target phase of the control signal for a given point in the welding process 1, 2 and 3 sequentially

**Page 2**

f min	Minimum frequency at which the generator can operate in both welding and scanning modes
f max	Maximum frequency at which the generator can operate in both welding and scanning modes
df	Frequency of starting point offset during the welding process
Power Reg	Switches the operation of the power and amplitude controller on or off
Power Reg Speed	Parameter that scales the speed of the power controller and amplitude
Res Reg Speed	Parameter to scale the frequency shearing grid step value of the frequency controller
E max	Maximum process energy after which the welding process is forced to end in cyclic energy welding mode
E thresh	Percentage of energy used to validate the energy input during the welding process
E check	Enables the validation of the energy input in the welding process if the process ends without applying an adequate amount of energy, the generator triggers a "energy" error
Sonotrode Pressure	Pressure value of pneumatic actuator controlling the sonotrode pressure to the welded workpiece, if the corresponding pressure controller is connected to the generator I/O card

**Page 3**

UB	Level of medium-delay voltage protection
P	Level of medium-delay output protection
IIA	Level of rapid current protection
IB	Level of medium-delay current protection
IC	Level of delay current protection
Tc	Level of thermal protection
Z min	Level of minimum impedance protection
Z max	Level of maximum impedance protection
Z min Start	Level of minimum start-up impedance protection
OvrCurrTresh	Not used

**4.1.3. Welding mode selection window**

The "Mode" window on **Page 1** of the **PROGRAMMES** menu offers a choice of one of the modes of operation described below.

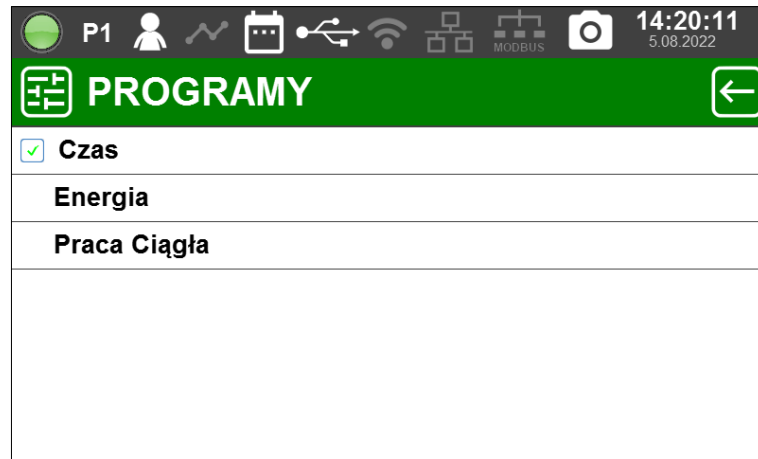

PROGRAMY	PROGRAMMES
Modbus	Modbus
Czas	Time
Energia	Energy
Praca Ciągła	Continuous operation

Fig. 10. Programmes -> Mode menu screen

Table 9 Available operating modes

Mode	Description
Continuous operation	Continuous operation with a set amplitude and power limiter. The generator sets the signal output amplitude to the set value (Amp). If the power output reaches the power limiter value (P), the amplitude is reduced so that the power does not exceed the set value.
Time	Welding takes place in a cyclical manner, with three welding time points with different process parameters. When the total time is exceeded, the process ends.
Energy	Cyclic operation with three welding time points with different process parameters. The welding process may end earlier than the total time of the welding process if an appropriate energy value is achieved.

#### 4.1.4. Numerical value editing window

The numerical value editing window (Fig. 11) pops up for editing numerical values, e.g. during programme setup.

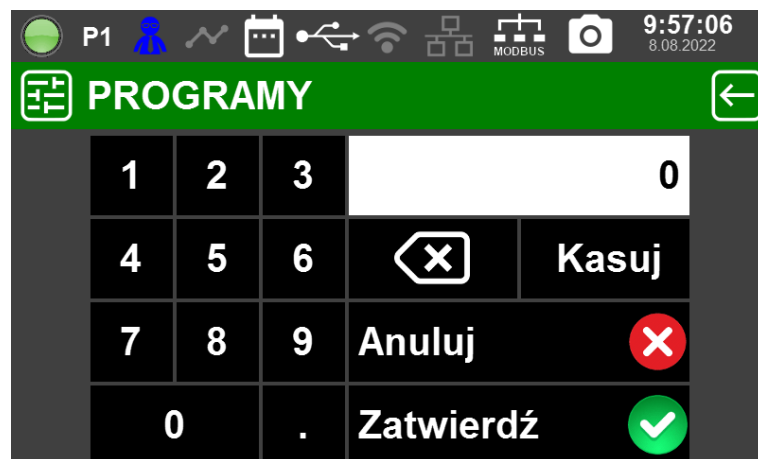

PROGRAMY	PROGRAMMES
Modbus	Modbus

Kasuj	Delete
Anuluj	Cancel
Zatwierdź	Accept

Fig. 11. Numerical value editing window

In order to enter a new field value, use the numeric keypad and accept the value. The value is changed immediately after acceptance. The icon functions are described in Table 10.

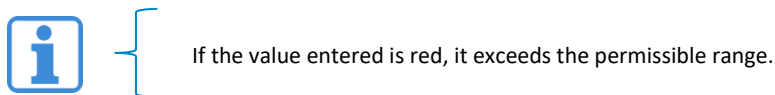

Table 10. Description of numerical value editing menu icons

Icon	Name	Description
	Back	Removes the last character.
	Delete	Removes the content of the text field.
	Cancel	Cancel the change to the entered value.
	Accept	Accept the change to the entered value.

#### 4th1st5th Measurement, protection and scanning results window

The MEASUREMENT window contains a list of entries divided into several pages. The individual pages can be navigated using the up/down arrow keys on the window title bar. The window is divided into three sections:

- SCANNING PARAMETERS, as presented in Fig. 12, in which measurement results are presented (see Table 11),
- MEASUREMENTS, as presented in Fig. 13, in which measurement results are presented (see Table 12),
- ERRORS, as presented in Fig. 14, in which measurement results are presented (see Table 13).



PARAMETRY SKANU	SCANNING PARAMETERS
Modbus	Modbus
Częstotliwość Szeregowa (fs)	Serial frequency (fs)
Impedancja Szeregowa (Zs)	Serial impedance (Zs)

Faza Szeregowa ( $\Phi$ )	Serial phase ( $\Phi$ )
Częstotliwość Równoległa ( $f_p$ )	Parallel frequency ( $f_p$ )
Impedancja Równoległa ( $Z_p$ )	Parallel impedance ( $Z_p$ )
Faza Równoległa ( $\Phi$ )	Parallel phase ( $\Phi$ )

Fig. 12. MEASUREMENT menu window in the SCANNING PARAMETERS section

Table 11. Description of the parameters in the MEASUREMENTS menu in the SCANNING PARAMETERS section

Parameter	Description
Ser. frequency ( $f_s$ )	Series resonance frequency of the vibration measured while scanning
Ser. impedance ( $ Z_s $ )	Impedance module for the vibration system for series resonance frequency
Ser. phase ( $\Phi$ )	Impedance phase for the vibration system for series resonance frequency
Par. frequency ( $f_p$ )	Parallel resonance frequency of the vibration measured while scanning.
Par. impedance ( $ Z_p $ )	Impedance module for the vibration system for parallel resonance frequency
Par. phase ( $\Phi$ )	Impedance phase for the vibration system for parallel resonance frequency

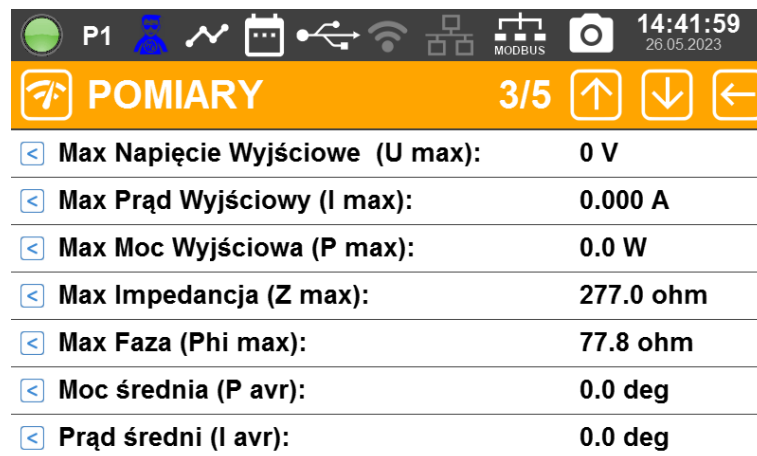

POMIARY 3/5	
Max Napięcie Wyjściowe (U max):	0 V
Max Prąd Wyjściowy (I max):	0.000 A
Max Moc Wyjściowa (P max):	0.0 W
Max Impedancja (Z max):	277.0 ohm
Max Faza (Phi max):	77.8 ohm
Moc średnia (P avr):	0.0 deg
Prąd średni (I avr):	0.0 deg

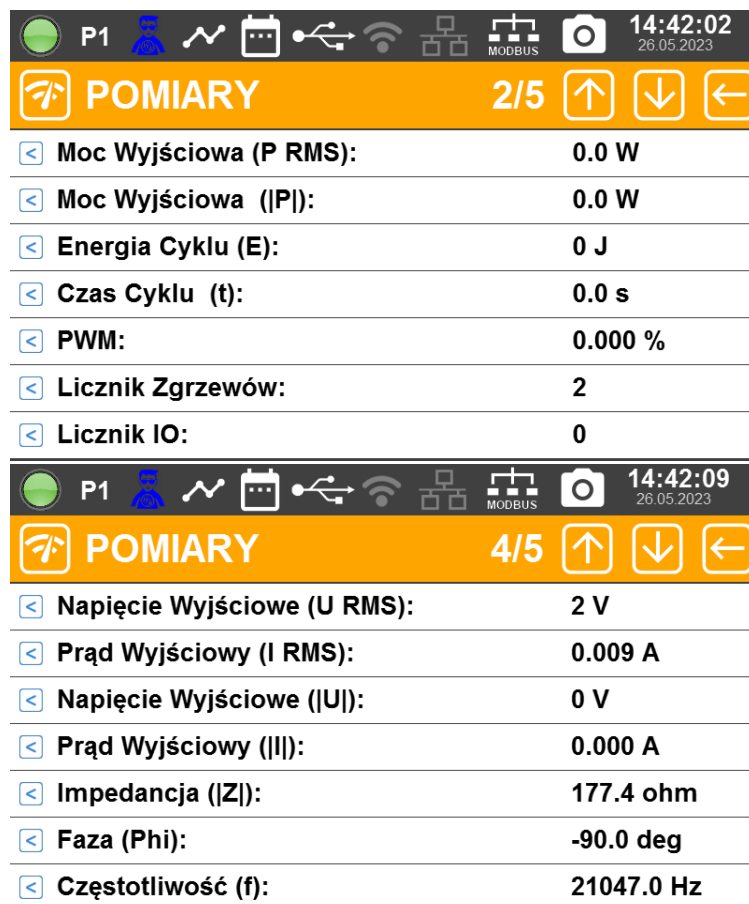

POMIARY	MEASUREMENTS
MODBUS	MODBUS
Max Napięcie Wyjściowe (U max)	Max. output voltage (U max)
Max Prąd Wyjściowy (I max)	Max. output current (I max)
Max Moc Wyjściowa (P max)	Max. power output (P max)
Max Impedancja (Z max)	Max. impedance (Z max)
Max Faza (Phi max)	Max. phase (Phi max)
Moc średnia (P avr)	Average power (P avr)
Prąd średni (I avr)	Average current (I avr)
Moc Wyjściowa (P RMS)	Power output (P RMS)
Moc Wyjściowa ( P )	Power output ( P )
Energia Cyklu (E)	Cycle energy (E)
Czas Cyklu (t)	Cycle Time (t)
PWM	PWM
Licznik Zgrzewów	Weld counter
Licznik IO	IO Counter
Napięcie Wyjściowe (U RMS)	Output voltage (U RMS)
Prąd Wyjściowy (I RMS)	Output current (I RMS)
Napięcie Wyjściowe ( U )	Output voltage in ( U )
Prąd Wyjściowy ( I )	Output current ( I )
Impedancja ( Z )	Impedance ( Z )
Faza (Phi)	Phase (Phi)
Częstotliwość (f)	Frequency (f)

Fig. 13. MEASUREMENT menu window in the MEASUREMENTS section

Table 12. Description of the parameters in the MEASUREMENTS menu in the MEASUREMENTS section

Parameter	Description
-----------	-------------

**Page 2**

Power output (P RMS)	Instantaneous generator power output value actually supplied to the load
Power output ( P )	Instantaneous generator power output value for the first harmonic signal
Cycle energy (E)	Value of energy accumulated during the welding cycle.
Cycle Time (t)	Welding cycle duration
PWM	Instantaneous output amplitude value
Weld Counter	Welding cycle trip count
IO Counter	Welding cycle trigger counter via internal automation card

**Page 3**

Max output voltage (U max)	Maximum root mean square output voltage during the process
MAX output current (I max)	Maximum root mean square output current during the process
Max power output (P max)	Maximum power output during the process
MAX impedance (Z max)	Maximum value of the load impedance module during the process
MAX phase (Phi max)	Maximum value of the load impedance phase during the process
Average power (P avr)	Average power value
Average current (I avr)	Average current value

**Page 4**

Output voltage (U RMS)	Instantaneous root mean square value of the output voltage
Output current (I RMS)	Instantaneous root mean square value of the load current
Output voltage ( U )	Instantaneous root mean square of the first harmonic output voltage
Output current ( I )	Instantaneous root mean square value of the first harmonic load current
Impedance ( Z )	Load impedance module
Phase (Phi)	Load impedance phase
Frequency (f)	Current output signal frequency.

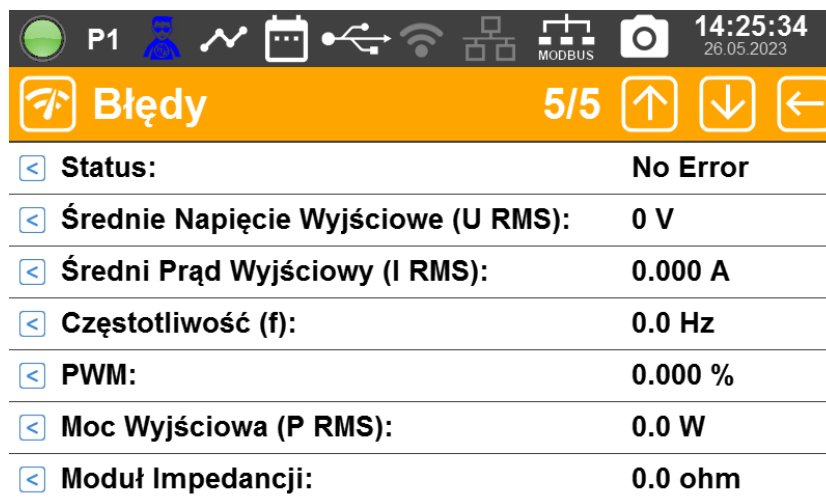

Modbus	Modbus
Błędy	Errors
Status	Status
Średnie Napięcie Wyjściowe (U RMS)	Average output voltage (U RMS)
Średni Prąd Wyjściowy (I RMS)	Average output Current (I RMS)
Częstotliwość (f)	Frequency (f)
PWM	PWM
Moc Wyjściowa (P RMS)	Power output (P RMS)
Moduł Impedancji	Impedance module
No Error	No Error

Fig. 14. MEASUREMENT menu window in the ERRORS section

Table 13. Description of the parameters in the MEASUREMENTS menu in the ERRORS section

Parameter	Description
Status	If a protection has been activated, the protection type is displayed.
Average output voltage (U RMS)	Root mean square value of the output voltage at protection activation.
Average output current (I RMS)	Root mean square value of the load current at protection activation.
Frequency (f)	Output frequency value at protection activation.
PWM	Amplitude value at protection activation.
Power output (P)	Power output value at protection activation.
Impedance ( Z )	Load impedance value at protection activation.

#### 4.1.6. Login window

The login window (Fig. 15) enables the user to log in using a numerical password (PIN). Users with different access rights can log in. The rights are ranked from lowest to highest:

USER X < ADMINISTRATOR < CLIENT SERVICE < ITR SERVICE

When a user with higher access rights logs in, it is possible to edit access passwords for users with lower access rights (Fig. 16). LOGIN menu icons and parameters are described in Table 14.



When the power supply is switched on, the user with the highest rights, with a password only containing zeros, is automatically logged in. If a given user is assigned with a password other than the one mentioned above, the automatic login function on power supply switch-on is disabled.

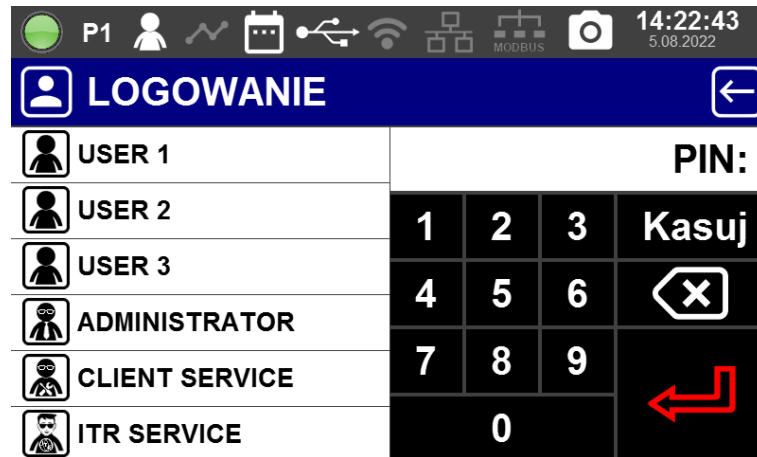

LOGOWANIE	LOGIN
USER	USER
ADMINISTRATOR	ADMINISTRATOR
CLIENT SERVICE	CLIENT SERVICE
ITR SERVICE	ITR SERVICE
PIN	PIN
Kasuj	Delete
Modbus	Modbus



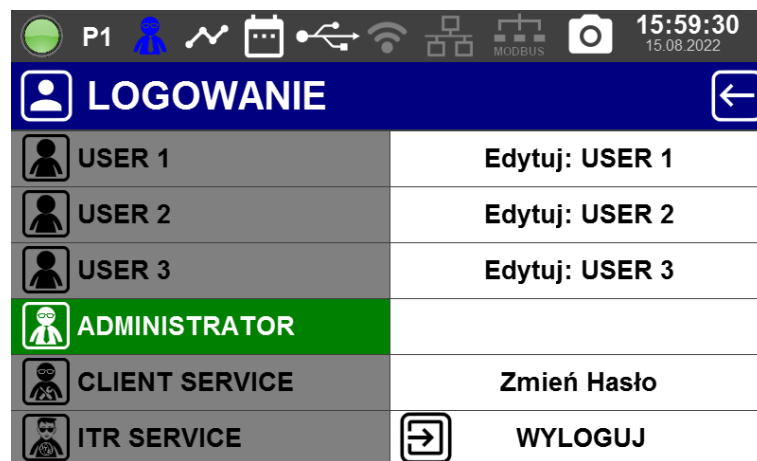

Fig. 15. User login window



LOGOWANIE	LOGIN
USER	USER
ADMINISTRATOR	ADMINISTRATOR
CLIENT SERVICE	CLIENT SERVICE
ITR SERVICE	ITR SERVICE
Modbus	Modbus
Edytuj: USER	Edit USER
Zmień Hasło	CHANGE PASSWORD
WYLOGUJ	LOG OUT

Fig. 16. Window of a logged-in user

Tab.14. Description of the LOGGING menu icons

Icon	Name	Description
	USER - USER	Icon for a user with USER rights.
	USER - CLIENT SERVICE	Icon for a user with CLIENT SERVICE rights.
	USER - ITR SERVICE	Icon for a user with ITR SERVICE rights.
	USER - ADMINISTRATOR	Icon for a user with ADMINISTRATOR rights.
Parameter		Description
CHANGE PASSWORD		Changes the password of a logged-in user.
Edit USER 1/ USER 2/ USER 3		Changes the password of a user with lower rights.
LOG OUT		Logs out the user.



In order to log in to the USER SERVICE user profile, you must contact the manufacturer and provide them with the code that is generated by clicking on the USER SERVICE icon. Then enter the disposable password provided by the manufacturer.

#### 4.1.7. Recorder window

In the recorder window (Fig. 17), it is possible to view the available recorder files, select the file to open, select up to 2 parameters for simultaneous display and enable/disable the display of a given chart. Chart settings, in which chart parameters can be modified, such as the range of data to be displayed, axis scaling, chart line thickness, logarithmic scale etc., are also available. When the recorder files are opened, numerous parameters are set automatically (such as logarithmic scale for scanning) and axes are scaled automatically. This facilitates the viewing of files.

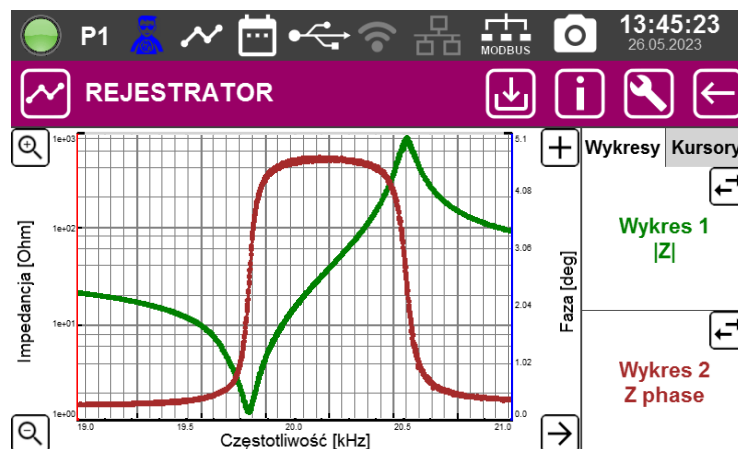









REJESTRATOR	RECORDER
MODBUS	MODBUS
Wykresy	Charts
Kursory	Cursors
Wykres	Chart

Z phase	Z Phase
Częstotliwość	Frequency
Faza	Phase
Impedancja	Impedance

Fig. 17. RECORDER window

Tab.15. Description of the RECORDER menu icons

Icon	Name	Description
	Recorder file selection	Press the icon to access the menu for selecting the file to be displayed on the chart.
	Graph param.	Press the icon to access the CHART PARAMETERS menu.
	File Description	Press the icon to display a preview of information about the currently viewed file
	Zoom In/Zoom out	Press the icon to zoom in or out of the currently displayed graph.
	Hide	Press the icon to hide the currently displayed Graphs/Cursors menu.
	Zoom In	Press the icon to expand the currently displayed chart to full screen.
	Changing the Displayed Parameter	Press the icon to access the menu for selecting the displayed parameter.
	External memory recording	The icon is only visible when a USB flash drive is plugged into the USB port. Press the icon to save the chart to the connected memory.

The file selection menu (Fig. 18) contains a selection item to decide whether scanning or welding processes are to be viewed and contains a file selection list. The list of files is displayed in the order of their creation. The number of file browser pages depends on the number of files.

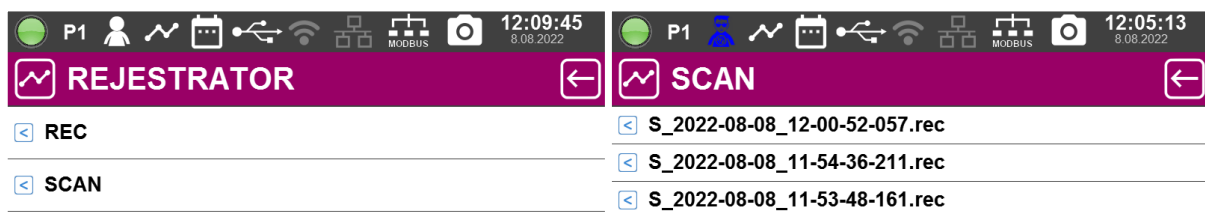

REJESTRATOR	RECORDER
SCAN	SCAN
MODBUS	MODBUS
REC	REC

Fig. 18. RECORDER file selection window

When a file to be displayed is selected, the data is retrieved from the file, the chart axes are automatically scaled and a set of default parameters is displayed. In scan view mode, the system impedance module in logarithmic scale and the impedance phase are displayed.

When the chart is displayed, it can be zoomed in using one of the two modes: chart key hidden mode or chart full screen mode. Fig. 19 shows the recorder window in partial full screen mode (with the chart key hidden) and in full screen mode.



REJESTRATOR	RECORDER
MODBUS	MODBUS
Wykresy	Charts
Kursory	Cursors
Wykres	Chart
Z phase	Z Phase
Częstotliwość	Frequency
Faza	Phase
Impedancja	Impedance
Zph	Zph
freq	freq

Fig. 19. Ultrasonic vibration system parameter chart window

The chart usually has one axis of abscissae (when viewing a scan file, this is the frequency axis, whereas in the case of a welding process file, this is the time expressed in milliseconds) and two axes of ordinates. Using the chart options (Fig. 20), it is possible to disable an additional axis of ordinates or select a scale (linear or logarithmic) and a series of chart graphical options.

P1  12:03:55  
8.08.2022

**UST. WYKRESU** 1/5 

<input type="checkbox"/> Rozmiar Krzywej:	3
<input type="checkbox"/> Rozmiar Punktu Krzywej:	6

P1  12:03:59  
8.08.2022

**UST. WYKRESU** 2/5 

<input type="checkbox"/> X1 Liczba Markerów:	5
<input type="checkbox"/> X1 Liczba Mniejszych Markerów:	5
<input type="checkbox"/> X1 Rysuj Tytuł:	<input checked="" type="checkbox"/>
<input type="checkbox"/> X1 Rysuj Markery:	<input checked="" type="checkbox"/>
<input type="checkbox"/> X1 Rysuj Mniejsze Markery:	<input checked="" type="checkbox"/>
<input type="checkbox"/> X1 Autoskalowanie:	<input checked="" type="checkbox"/>

P1  12:04:04  
8.08.2022

**UST. WYKRESU** 3/5 

<input type="checkbox"/> Y1 Liczba Markerów:	6
<input type="checkbox"/> Y1 Liczba Mniejszych Markerów:	5
<input type="checkbox"/> Y1 Rysuj Tytuł:	<input checked="" type="checkbox"/>
<input type="checkbox"/> Y1 Rysuj Markery:	<input checked="" type="checkbox"/>
<input type="checkbox"/> Y1 Rysuj Mniejsze Markery:	<input checked="" type="checkbox"/>
<input type="checkbox"/> Y1 Autoskalowanie:	<input checked="" type="checkbox"/>
<input type="checkbox"/> Y1 Skala Logarytmiczna:	<input checked="" type="checkbox"/>



UST. WYKRESU	PARAM. CHART
Modbus	Modbus
Rozmiar Krzywej	Size curve
Rozmiar Punktu Krzywej	Size of the curve point
Liczba Markerów	Number of markers
Liczba Mniejszych Markerów	Number of minor markers
Rysuj Tytuł	Draw title
Rysuj Markery	Draw markers
Rysuj Mniejsze Markery	Draw minor markers
Autoskalowanie	Autoscaling
Skala Logarytmiczna	Logarithmic scale

Fig. 20. Diagram Setting Windows

After clicking on the File Description icon , the user can view information about the file currently being viewed (Fig. 21). The File Description window contains a list of entries divided into two pages. The individual pages can be navigated using the up/down arrow keys on the window title bar.

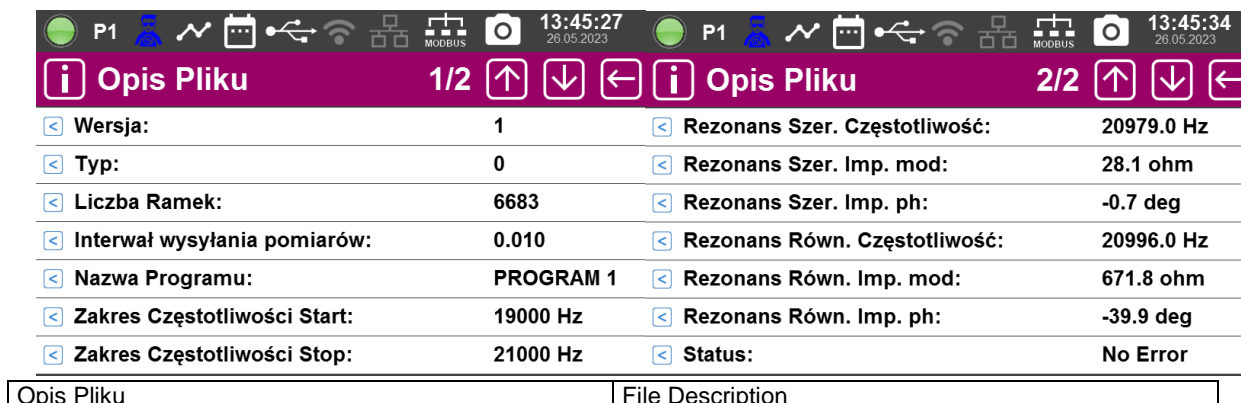

Opis Pliku	File Description
------------	------------------

Modbus	Modbus
Wersja	Version
Typ	Type
Liczba Ramek	Frame count
Interwał wysyłania pomiarów	Send measurement interval
Nazwa Programu	Programme Name:
Zakres Częstotliwości Start	Start Frequency Range
Zakres Częstotliwości Stop	Stop Frequency Range
PROGRAM	PROGRAMME
Rezonans Szer. Częstotliwość	Resonance Width Frequency
Rezonans Szer. Imp. mod	Resonance Width Imp. mod
Rezonans Szer. Imp. ph	Resonance Width Imp. ph
Rezonans Równ. Częstotliwość	Resonance Equiv. Frequency
Rezonans Równ. Imp. mod	Resonance Equiv. Imp. mod
Rezonans Równ. Imp. ph	Resonance Equiv. Imp. ph
Status	Status
No Error	No Error

Fig. 21. File Description Windows

When the chart has been loaded, data provided in a given display can be selected and a given chart may be enabled or disabled. A total of 2 charts can be used. Each of them can present one of the 18 available parameters. Figure 22 shows the parameter selection window to display available by pressing the Change Displayed Parameter icon .

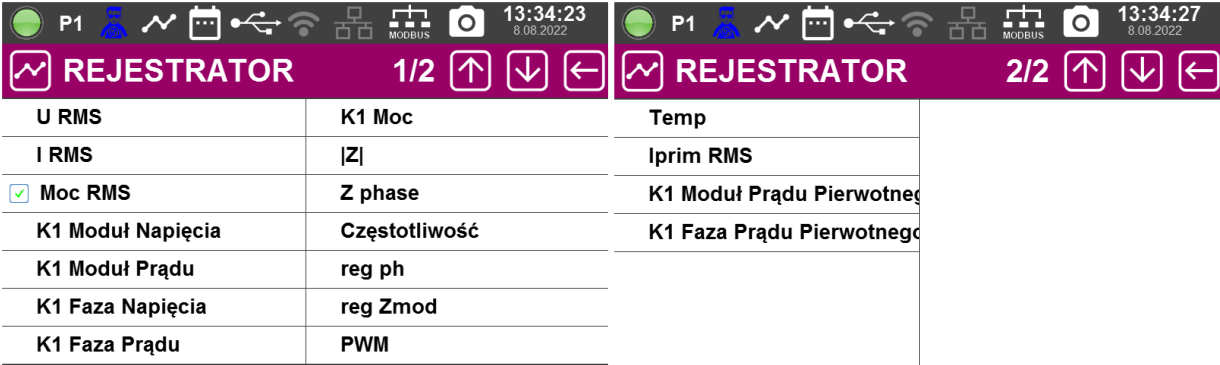

REJESTRATOR	RECORDER
Modbus	Modbus
U RMS	U RMS
I RMS	I RMS
Moc RMS	RMS power
K1 Moduł Napięcia	K1 Voltage module
K1 Moduł Prądu	K1 Current module
K1 Faza Napięcia	K1 Voltage phase
K1 Faza Prądu	K1 Current phase
K1 Moc	K1 Power
Z phase	Z Phase
Częstotliwość	Frequency
reg ph	reg ph
reg Zmod	reg Zmod
PWM	PWM
Temp	Temp
Iprim RMS	Iprim RMS
K1 Moduł Prądu Pierwotnego	K1 Primary current module
K1 Faza Prądu Pierwotnego	K1 Primary current phase

Fig. 22 Parameter selection windows to display

For easier and more precise reading of the data from the recorder, the graphs are equipped with cursors. Click anywhere on the graph to place the cursor at the specified point. The selection of the active cursor and the value preview are available in the cursors tab on the right side of the screen (Fig. 23).



Modbus	Modbus
Impedancja	Impedance
Faza	Phase
Częstotliwość	Frequency
Wykresy	Charts
Kursory	Cursors
Kursor	Cursor

Fig. 23. Cursors Window

### 4.1.8. Event log window

The EVENT LOG menu (Fig. 24) contains the list of events along with the date and time of occurrence. When the event is started, it is possible to view details of the specific event (Fig. 25).

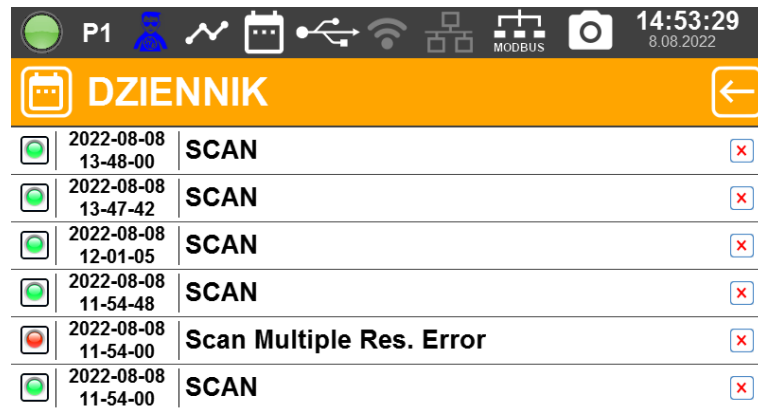

DZIENNIK	LOG
Scan Multiple Res. Error	Scan Multiple Res. Error
SCAN	SCAN
Modbus	Modbus

Fig. 24. Event log window

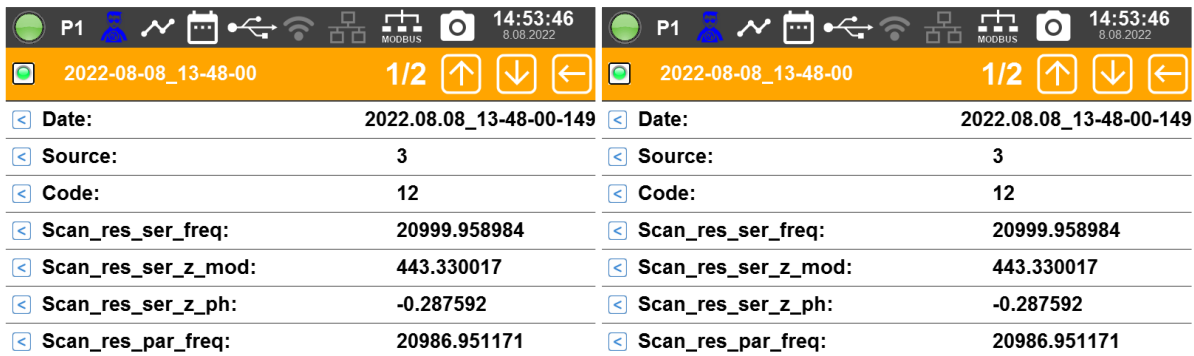

Date	Date
Source	Source
Code	Kod
Modbus	Modbus

Fig. 25. Event specific details window in the event log

### 4.1.9. Settings Window

THE SETTINGS menu (Fig. 26) lists the items of each function. After selecting interesting functionality, the user can change selected parameters.

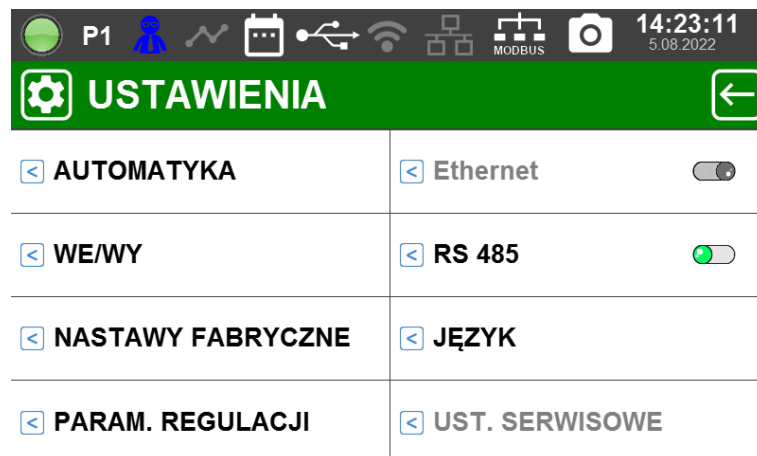

USTAWIENIA	SETTINGS
Modbus	Modbus
AUTOMATYKA	AUTOMATION
WE/WY	I/O
NASTAWY FABRYCZNE	FACTORY SETTINGS
PARAM. REGULACJI	PARAM. OF CONTROL
Ethernet	Ethernet
RS 485	RS 485
JEZYK	LANGUAGE
UST. SERWISOWE	PARAM. OF SERVICE

Fig. 26. Settings Window

## AUTOMATION

The *AUTOMATION* menu (Fig. 27) contains a list of entries divided into 4 pages. The individual pages can be navigated using the up/down arrow keys on the window title bar. THE *AUTOMATION* menu allows to configure logic states of I/O and to assign selected I/O inputs and outputs available on the I/O card to specific functionalities.

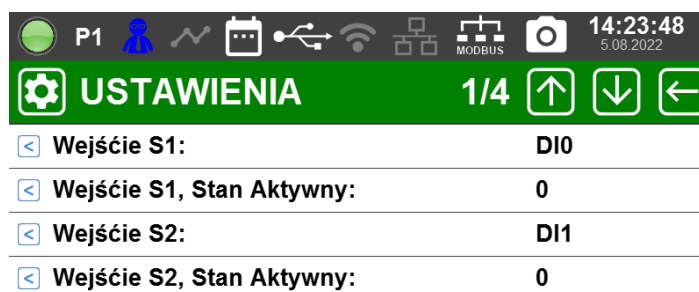



<	Wejście Osłony:	DI3
<	Wejście Osłony, Stan Aktywny:	1
<	Wejście Sonotrody:	DI2
<	Wej. Sonotrody, Stan Aktywny:	1



<	Wyjście Osłony:	DO0
<	Wyjście Osłony, Stan Aktywny:	0
<	Wyjście Sonotrody:	DO1
<	Wyj. Sonotrody, Stan Aktywny:	0
<	Wyjście Gotowości:	DO2
<	Wyj. Gotowości, stan Aktywny:	0



<	Wyjście Sygnalizacji Pracy:	DO3
<	Wyj. Sygn. Pracy, st. Aktywny:	0
<	Wyjście Błędu:	DO4
<	Wyjście Błędu, stan Aktywny:	0
<	Wej. Odczytu reg. ciśnienia:	AI0
<	Wyj. nastawy reg. ciśnienia:	AO0

Modbus	Modbus
USTAWIENIA	SETTINGS
Wejście S1, Stan Aktywny	Input S1, Active Status
Wejście S2	Input S2
Wejście Osłony	Input Cover
Wejście Osłony, Stan Aktywny	Lighting Input, Active Status
Wejście Sonotrody	Sonotrody Input
Wej. Sonotrody, Stan Aktywny	In. SonotrodES, Active Status
Wyjście Osłony	Output Cover
Wyjście Osłony, Stan Aktywny	Output Cover, Status Active
Wyjście Sonotrody	Sonotrode Output
Wyj. Sonotrody, Stan Aktywny	Out SonotrodES, Active Status
Wyjście Gotowości	Output Ready
Wyj. Gotowości, stan Aktywny	Output Ready, Active State
Wyjście Sygnalizacji Pracy	Operation Signal Output
Wyj. Sygn. Pracy, st. Aktywny	Output Sign. Work, Active St.
Wyjście Błędu	Output Error
Wyjście Błędu, stan Aktywny	Output Error, Active State
Wej. Odczytu reg. Ciśnienia	In. Reg. readout Pressures
Wyj. nastawy reg. Ciśnienia	Reg. setpoint out Pressures

Fig. 27. AUTOMATICS window

## I/O

The I/O window (Fig. 28) allows viewing the current states on the I/O card inputs and outputs and reading the parameters of the card. A description of the icons and parameters of the I/O menu is provided in Table 16.

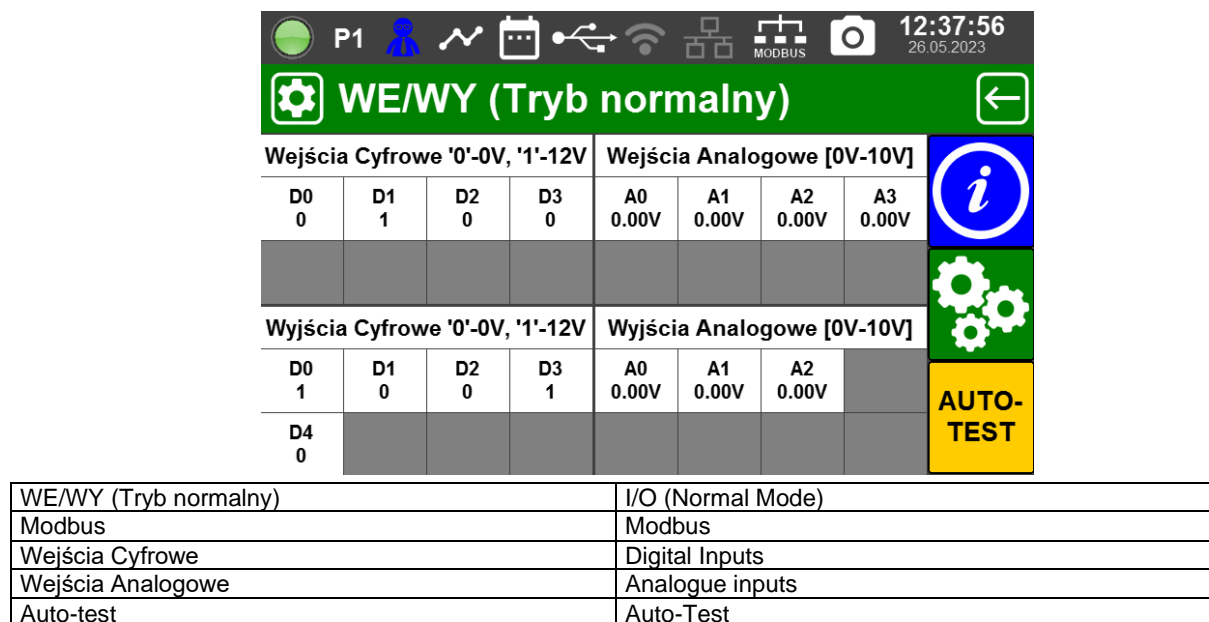

Fig. 28. I/O window

Table 16. Description of the SETTINGS menu parameters of the I/O window

Icon	Name	Description
	I/O INFO	Press the icon to display information about the I/O card
	Mode change	Press the icon to switch between normal and manual modes Normal Mode - Preview Only Mode Manual mode — which allows to change the values of digital and analog outputs (when clicked to the selected value) Manual mode is available only from the ADMINISTRATOR login
	AUTO-TEST	Auto I/O Test

## FACTORY SETTINGS

The FACTORY SETTING window allows restoring the default settings. When the user presses the FACTORY SET-POINT BUTTON, a selection window appears (Fig. 29). To restore the default settings, press THE Yes button.



Modbus	Modbus
USTAWIENIA	SETTINGS
NASTAWY FABRYCZNE	FACTORY SETTINGS
Tak	Yes
Nie	no
AUTOMATY	AUTOMATION SYSTEMS
WE/WY	I/O
NASTAWY	SETTINGS
PARAM. REGULACJI	PARAM. OF CONTROL
UST. SERWISOWE	PARAM. OF SERVICE

Fig. 29. Factory SETTINGS WINDOW

## PARAM. OF CONTROL

Access to the PARAM OF CONTROL window is possible only from the SERVICE USER and the ITR SERVICE USER and under the supervision of the manufacturer. To access the adjustment parameters available in the PARAM OF CONTROL window, contact the manufacturer.

## Ethernet

The ON/OFF switch next to the Ethernet window allows Ethernet communication to be switched on or off. Parameters related to this functionality can be changed by the user pressing the Ethernet button. The available configurable parameters (Fig. 30), are described in Table 22.

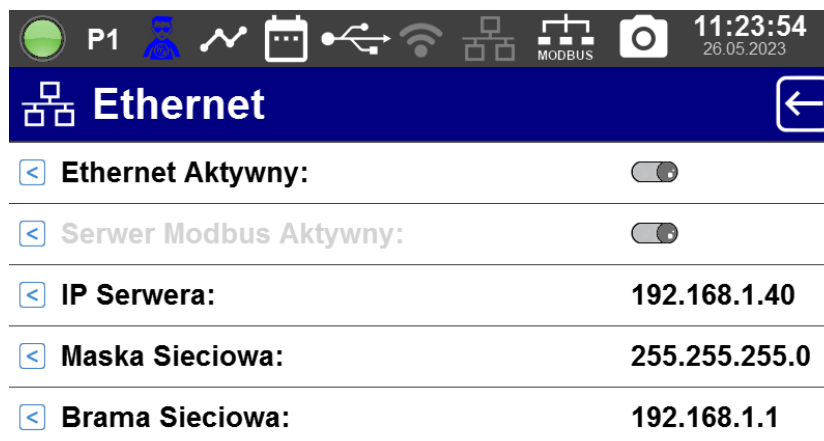

Modbus	Modbus
Ethernet	Ethernet
Ethernet Aktywny	Ethernet Active
IP Serwera	Server IP
Maska Sieciowa	Network mask
Brama Sieciowa	Network Gateway
Serwer Modbus Aktywny	Modbus Server Active

Fig. 30. Ethernet window

Table 22. Description of the SETTINGS *USTAWIENIA* menu of the Ethernet window

Parameter	Description
Ethernet Active:	The ON/OFF switch located allows the ETHERNET communication to be activated and deactivated
Modbus Server Active:	The ON/OFF switch located allows the Modbus Server to be activated and deactivated
IP Server:	Server IP Address
Network Mask:	Subnet mask
Network Gateway:	Network gateway IP address

## RS 485

The ON/OFF switch next to RS 485 allows the RS 485 communication to be switched on or off. The parameters related to this functionality can be changed by pressing the RS 485 button by the user. Available configurable parameters (Fig. 31) are described in Tab. 22.

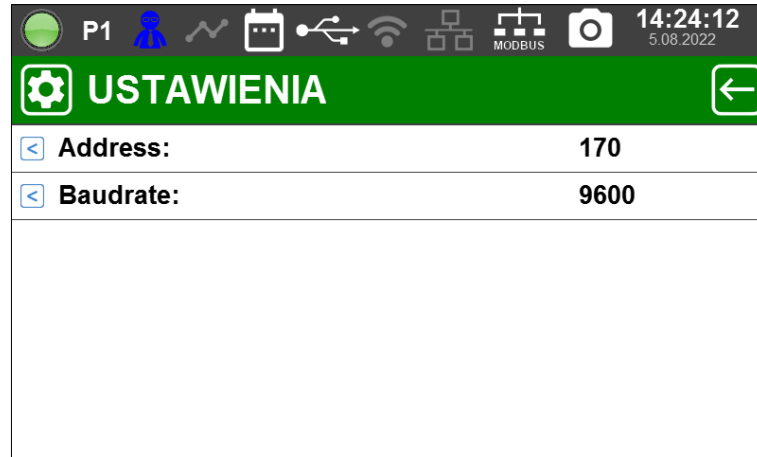

Modbus	Modbus
USTAWIENIA	SETTINGS
Address	Adres
Baudrate	Baudrate

Fig. 31. RS 485 window

Table 22. Description of parameters of the *SETTINGS* menu in the RS 485 window

Parameter	Description
Adres:	Device address
Baudrate:	Communication speed

## LANGUAGE

The LANGUAGE window allows selecting one of the three available display languages: Polish, English, Serbian. By clicking in the selected language, a tag of the active parameter should appear next to it  (Fig. 32).

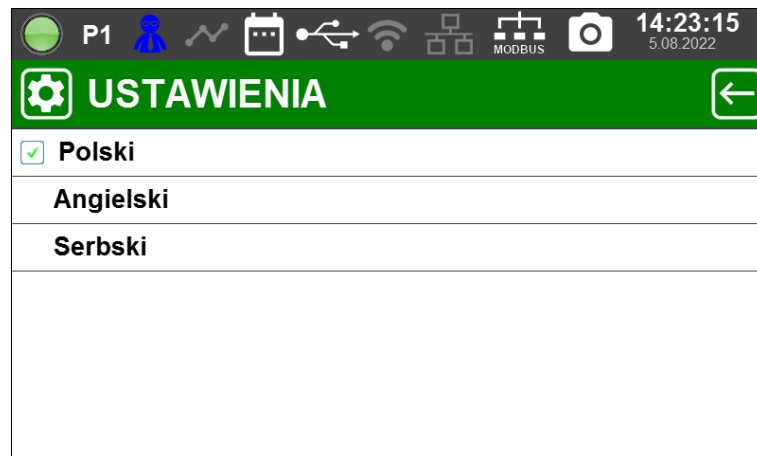

Modbus	Modbus
USTAWIENIA	SETTINGS
Polski	Polish
Angielski	English
Serbski	Serbian

Fig. 32. LANGUAGE window

## PARAM. OF SERVICE

Access to the PARAM. OF SERVICE window is possible only from the SERVICE USER and the ITR SERVICE USER levels and under the supervision of the manufacturer. For access to the service settings available in the PARAM. OF SERVICE window contact the manufacturer.

### 4.1.10. Date and time setting window

The date and time setting window (Fig. 33) allows changing the system date and time by clicking on the Date and Time window respectively.

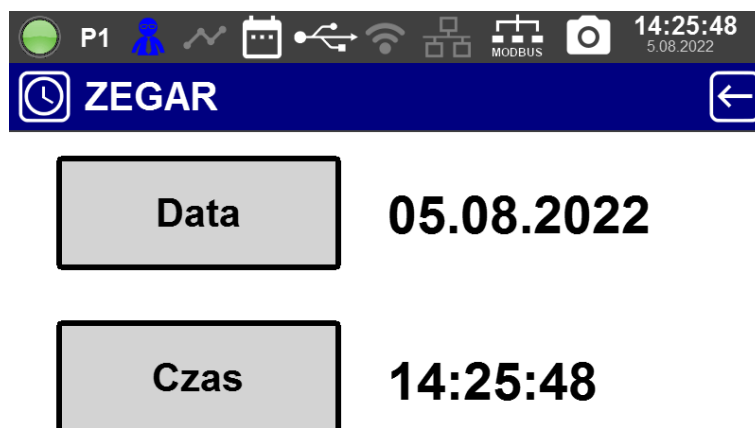

MODBUS	MODBUS
ZEGAR	CLOCK
Data	Date
Czas	Time

Fig. 33. Date and time setting window

### 4.1.11. Help Window

The HELP window (Fig. 34) allows the model and the current hardware and software version of both the panel and the generator board to be viewed. Once in the HELP window, the user also has access to the manufacturer's contact details.



POMOC	HELP
Modbus	Modbus

Typ: Sonic blaster plus	Type: Sonic blaster plus
Model	Model
Wersja Sprzętu	Hardware Version
Wersja Oprogramowania	Software Version
SIEC BADAWCZA ŁUKASIEWICZ - INSTYTUT TELE-I RADIOTECHNICZNY	RESEARCH NETWORK ŁUKASIEWICZ - TELE AND RADIO RESEARCH INSTITUTE
INSTYTUT BADAWCZY KATEGORIA A	RESEARCH INSTITUTE CATEGORY A
Ratuszowa 11, 03-450 Warszawa	Ratuszowa 11, 03-450 Warsaw
tel	Phone
Instytut jest jednostką notyfikowaną przez Komisję Europejską o numerze 1941	The Institute is a European Commission notified body under the number 1941
Łukasiewicz Instytut Tele-I Radiotechniczny	Łukasiewicz – Tele and Radio Research Institute at the 32nd

Fig. 34. Help Window

## 4.2. Generator Update

### Preparing update file

In order to perform the update, download the update files received by the manufacturer and place them in the root folder of the flash drive type memory.

WARNING: Before performing the update, it is recommended to back up the generator settings as instructed in section 4.3.

### USB icon

Icon	Name	Description
	USB	Icon for enabled/disabled USB communication. Press the icon to access the USB selection menu

If a USB flash drive has been detected in the USB type A port on the front panel of the generator, the USB icon should light up in the quick access icon bar. If the USB icon is not detected in the USB port of the memory, it will be greyed out.

Press the USB icon to access the USB Menu.

### USB Menu

The selection of the Software Update item from the USB Menu (Fig. 35.) takes you to the Software Update Menu.

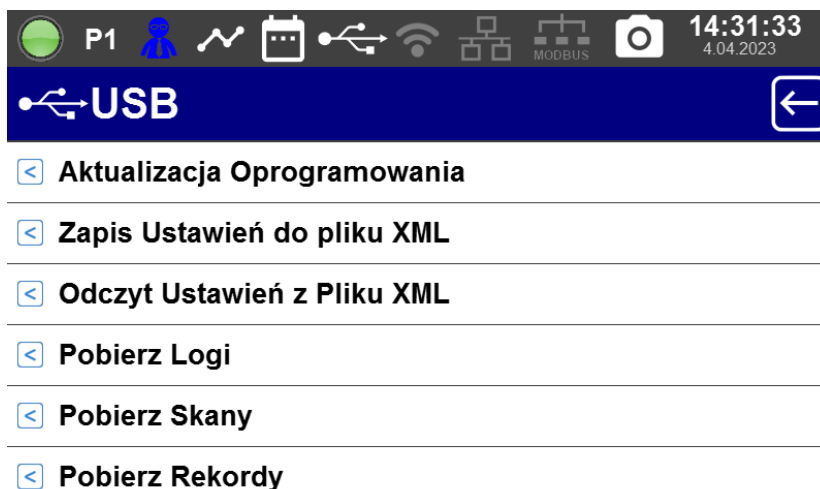

Modbus	Modbus
USB	USB
Aktualizacja Oprogramowania	Software Update
Zapis Ustawień do pliku XML	Saving the Settings to an XML file
Odczyt Ustawień z Pliku XML	Reading settings from an XML file
Pobierz Logi	Download Logs
Pobierz Skany	Download Scans
Pobierz Rekordy	Download Records

Rys.35. USB Menu Window View

## Software Update Menu

To update, use the Upgrade Software Menu (Fig. 36.) to indicate which system components you want to update, and then confirm the update command with the button YES in the confirmation window.

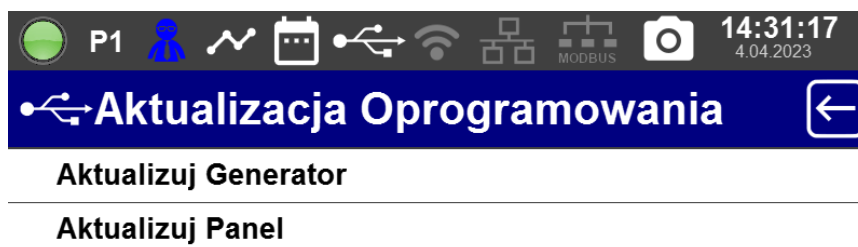

Modbus	Modbus
Aktualizacja Oprogramowania	Software Update
Aktualizuj Generator	Update Generator
Aktualizuj Panel	Update Panel

Fig. 36. SoftwareUpdate Menu View

## 4th3rd Preparing a backup of the generator settings

In order to prepare a backup copy of the generator settings, a USB memory stick type should be plugged into the USB socket (Fig.1.-B) located on the front panel of the SBP generator.

## USB icon

Icon	Name	Description
	USB	Icon for enabled/disabled USB communication. Press the icon to access the USB selection menu

If a USB flash drive has been detected in the USB type A port on the front panel of the generator, the USB icon should light up in the quick access icon bar. If the USB icon is not detected in the USB port of the memory, it will be greyed out.

Press the USB icon to access the USB Menu.

## USB Menu

To back up the Sonic Blaster Plus generator settings, press the Save Settings to XML file item (Fig. 37). The copy file will be saved on a Flash Drive.

To upload the backup to another Sonic Blaster Plus generator, plug the memory stick with the previously prepared backup file into the generator and select Read Settings from XML File in the USB menu.

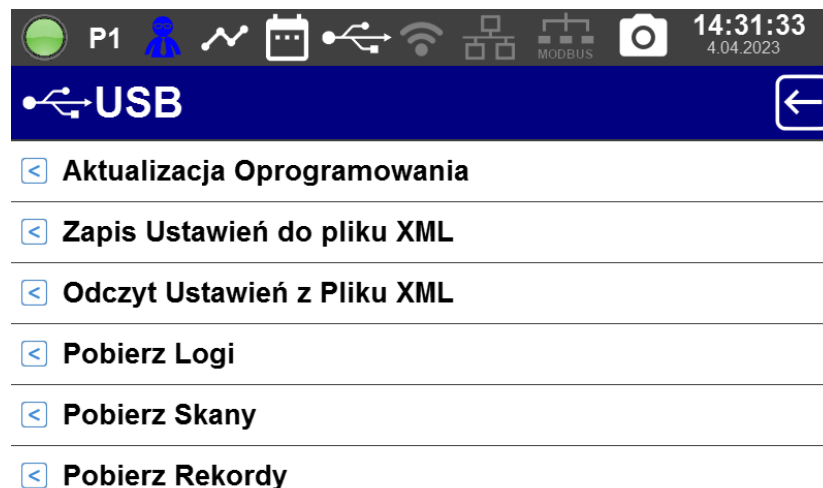



Modbus	Modbus
USB	USB
Aktualizacja Oprogramowania	Software Update
Zapis Ustawień do pliku XML	Saving the Settings to an XML file
Odczyt Ustawień z Pliku XML	Reading settings from an XML file
Pobierz Logi	Download Logs
Pobierz Skany	Download Scans
Pobierz Rekordy	Download Records

Fig. 37. USB Menu Window View

## 4.4. Generator start

Before starting the generator, it should be checked if it was properly connected to the ultrasonic process station. Particular attention should be paid to the correctness and reliability of the connection of the generator to the vibration system using the HV cable. In order to start the generator, switch on the generator's power supply with the power switch installed on the generator's rear panel. When the power supply is switched on, the POWER SUPPLY  symbol lights up, a double audible signal is generated

and the main menu appears on the device’s display. Each time the power supply is switched on, the generator performs a scan process of the vibration system. This process is indicated by the illumination of the OPERATION  symbol on the generator’s rear panel. If the WELDING item (marked in red in the main menu) is selected, variations of excitation frequency of the vibration system within a set generator operating range are observed. This procedure is aimed at defining the operating parameters of the vibration system and eliminates the need to set these parameters manually. At the same time, the procedure ensures that the correctness and efficiency of the connection of the generator to the vibration system are controlled.

If the tuning procedure has been completed successfully, the generator is switched to standby mode, which is indicated by the illumination of the STANDBY  symbol. Otherwise, the standby symbol remains off and the generator does not allow the welding process to be started.

When the aforementioned operations are performed, the generator is ready for operation. The welding cycle is started after forcing a correct start signal at the binary inputs of the I/O card (see section 4.3.2), sending a start command using MODBUS RTU (if active, see section 4.4) or from the control panel using the START key in the WELDING menu.



In order to switch off the generator’s power supply, use the power switch installed on the generator’s rear panel. It is not recommended to switch off the generator’s power supply when the HV output signal is generated. It is acceptable only in exceptional situations, such as a threat to the life or health of the operator, risk of fire, process line failure etc. The generation of the HV output signal is indicated by the illumination of the OPERATION  symbol on the generator’s rear panel.



In order to switch off the generator’s power supply, use the power switch installed on the generator’s rear panel. It is not recommended to switch off the generator’s power supply when the HV output signal is generated. It is acceptable only in exceptional situations, such as a threat to the life or health of the operator, risk of fire, process line failure etc. The generation of the HV output signal is indicated by the illumination of the OPERATION symbol on the generator’s rear panel.



The factory default password for Administrator rights contains zeros only, which means that the generator logs in automatically as the Administrator. In order to restrict access to advanced generator functions for unauthorised persons, change the Administrator password.

## 5. Technical data

Parameter	Sonic Blaster Plus					
	SBP220	SBP320	SBP520	SBP230	SBP240	SBP250
Supply voltage	~230 V AC, 50 Hz					
Power consumption	2.5 kVA	3.5 kVA	5.5 kVA	2.5 kVA	2.5 kVA	2.5 kVA
Operating frequency range	18 – 25 kHz			25 kHz – 35 kHz	35 kHz – 45 kHz	45 kHz – 55 kHz
Power output	2 kW	3 kW	5 kW	2 kW	2 kW	2 kW

Binary inputs (0-24 V)	
Number of inputs	4
Minimum excitation voltage	5 V DC
Input current consumption	< 12 mA at 24 V
Interface type	DB15M

<b>Binary (relay) outputs</b>	
Number of outputs	5
Breaking capacity at resistive load	---24 V DC; 1 A; ~48 V AC; 2 A;
Interface type	DB15M
<b>Analogue inputs</b>	
Number of inputs	4
Range of measured voltages	0-10 V DC
Input impedance	40 k $\Omega$
Interface type	DB9M
<b>Analogue outputs</b>	
Number of outputs	3
Range of measured voltages	0-10 V DC
Interface type	DB15M
<b>Clock</b>	
Clock accuracy	$\leq 1.5$ min/month
<b>Ingress protection</b>	
Housing ingress protection	IP30
Protection rating	I
<b>Weight and dimensions</b>	
Ground	12 kg
Width/height/depth	373/157/383 mm (Fig. 22)
<b>Environmental conditions</b>	
Operating temperature	0°C ... +45°C
Storage temperature	-30°C ... +70°C
Humidity	$\leq 75\%$ (at 20°C)
Standard equipment	<ul style="list-style-type: none"> <li>• HV cable</li> <li>• Power cable with IEC C19 connector</li> <li>• Operating manual</li> </ul>

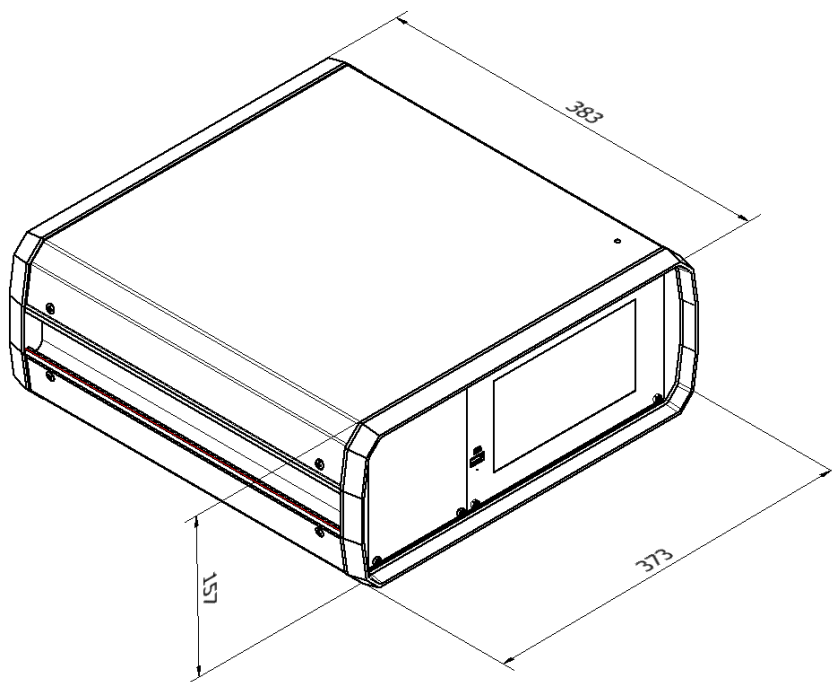
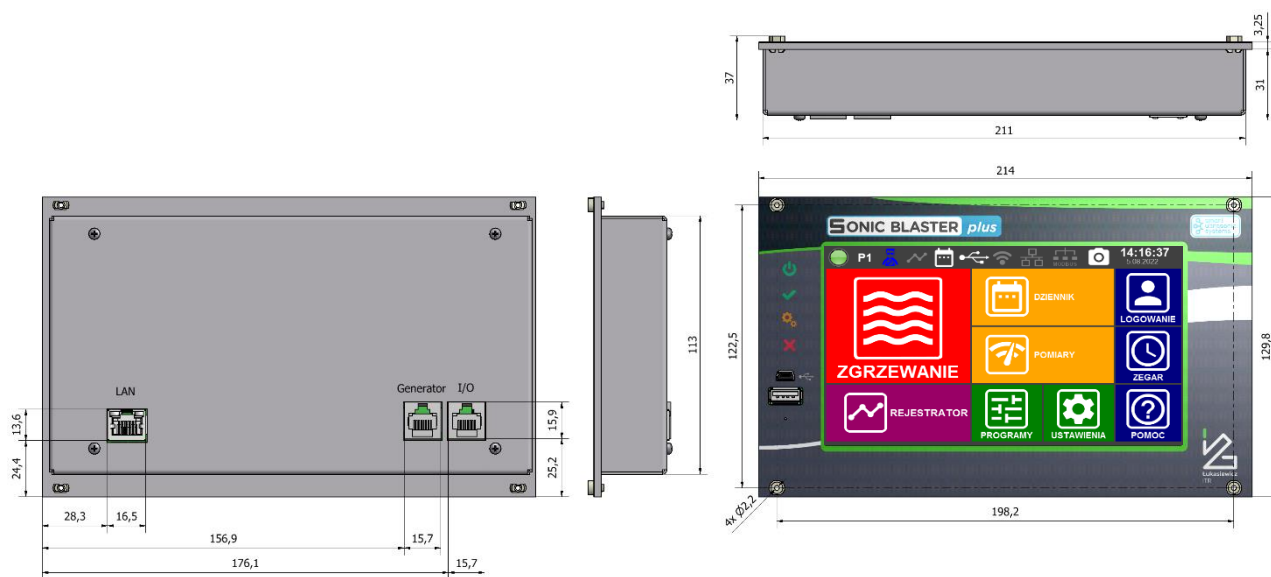

Fig. 38. SONIC BLASTER Plus generator dimensions



Generator	Generator
ZGRZEWANIE	WELDING
REJESTRATOR	RECORDER
DZIENNIK	LOG
POMIARY	MEASUREMENTS
PROGRAMY	PROGRAMMES
USTAWIENIA	SETTINGS
LOGOWANIE	LOGIN
ZEGAR	CLOCK
POMOC	HELP
Modbus	Modbus

Fig. 39. Dimensions of the SONIC BLASTER Plus detachable generator panel

## 6. Manufacturer's comments

### 6.1. Maintenance, periodic inspections and repairs



Maintenance operations can be performed by the user after disconnecting the generator from the mains and disconnecting the control connections and the vibration system connections. Generator maintenance involves periodic cleaning of the front panel using a dry or damp cloth. It is not permitted to clean the generator by dismantling it or by disassembling any component of its housing. The generator is equipped with a housing to protect against the ingress of dust to the inside and to enable proper cooling. The generator's cooling fans, located at its rear panel, are equipped with dust filters. When the filters are dirty, they should be cleaned or replaced.



To remove the dust filters, pull the plastic filter housings. They are latch-mounted. When the filtration sponges are cleaned or replaced, they should be reinstalled.



If the dust filters are removed, the generator power supply cannot be switched on.



The housing's vents should never be covered when the generator is in operation.



If any anomalies in the operation of the generator are observed, please contact the manufacturer. The generator should only be repaired and inspected by the manufacturer.

The SONIC BLASTER Plus generator has an integrated battery to back up the memory and real-time clock. The battery life is intended for 10 years of generator operation or 5 years of storage. It is recommended that the generator be returned to the manufacturer for battery replacement and inspection within 5 years of manufacture or last inspection.

### 6.2. List of spare parts delivered on request

- HV cable (connecting the generator to the vibration system) with LEMO connectors;
- 2 m power cable with IEC C19 connector;
- Dust filter filtration sponges.

### 6.3. OHS instructions

The generator plug's ground pin must be effectively connected to the electrical system protection circuit using a Cu conductor with a cross-section not less than 2.5 mm<sup>2</sup>.

The HV cable that connects the SONIC BLASTER Plus generator to the vibration system should not have any signs of insulation damage. A damaged cable should be immediately replaced with a new one, supplied by the manufacturer. It is forbidden to use the generator with a damaged HV cable, to repair the cable or to use a cable other than that supplied by the manufacturer.

Employees who operate the SONIC BLASTER Plus generator must read the operating manual and use appropriate tools and protective equipment intended for working with ultrasonic technologies. In particular, if the ultrasonic machine does not ensure an adequate degree of protection, employees must use ear protection.

All repairs may only be carried out by the manufacturer.

### 6.4. Storage and transport

The SONIC BLASTER Plus generator should be stored indoors under normal environmental conditions. The indoor atmosphere should be free from aggressive vapours.



The generator should be shipped in the original packaging provided by the manufacturer. If the generator is protected against getting wet, frost, contamination and mechanical damage, it can be shipped using any means of transport. Particular attention should be paid to protecting the HV cable. Following any transport under conditions other than the operating conditions, prior to its start-up, the generator requires 24-hour re-conditioning at room temperature. This applies in particular to transport in conditions of increased humidity or temperature changes that may lead to condensation.

## 6.5. Disposal



This device cannot be disposed of with household waste. The user is responsible for the recycling and separate disposal of this type of device. The aforementioned waste should be collected in containers intended for recycling of waste electrical and electronic equipment. If the user has inadequate knowledge in this respect, he/she should consult the relevant local authorities or a waste disposal company.



## GUARANTEE CARD

The quality warrantor of the SONIC BLASTER Plus module is its manufacturer: Sieć Badawcza Łukasiewicz – Instytut Tele- i Radiotechniczny with its registered office at ul. Ratuszowa 11; 03-450 Warszawa.

In the event that any defects arise in the SONIC BLASTER Plus ultrasonic welding module with serial no. .... defects due to the fault of the Manufacturer: Łukasiewicz Research Network – Tele- and Radio Research Institute, he undertakes to remove them free of charge within 21 working days from the date of delivery of the welding module to the registered office of the Manufacturer.

If the Manufacturer finds that the module has not been operated in accordance with the User Manual. The manufacturer shall have the right to refuse to honour the warranty.

The purchaser is entitled to the manufacturer's warranty for a period of 12 months from the date of purchase of the equipment.

The warranty does not cover components which, when used in accordance with the instructions, are subject to natural wear and tear and are a consumable part before the end of the warranty period. Damage resulting from incorrect installation or use not in accordance with the operating instructions or lack of maintenance. Damage caused by working with inappropriate tools, using spare parts unsuitable for the type of appliance or by unauthorised persons carrying out repairs.

The warranty for the goods sold does not exclude, limit or suspend the rights of the buyer under the provisions of the Civil Code or the Act on Consumer Rights of 30 May 2014.

Date of sale:

Signature:

List of guarantee repairs			
Item	Component replaced	Date of replacement	Comments

## 7. Contact us



**Łukasiewicz**  
Instytut Tele-  
i Radiotechniczny

**ŁUKASIEWICZ RESEARCH NETWORK  
TELE AND RADIO RESEARCH INSTITUTE**

ul. Ratuszowa 11  
03-450 Warszawa

Telephone: +48 22 590 73 74

e-mail: [ultradzwieki@itr.lukasiewicz.gov.pl](mailto:ultradzwieki@itr.lukasiewicz.gov.pl)

www: [przemysl.itr.org.pl](http://przemysl.itr.org.pl)